

FLOW CHART FOR CHOOSING YOUR SYSTEM

Management of dairy shed effluent is mandatory for all dairies in South Australia. Management involves the collection, treatment, and spreading of effluent. How the effluent is collected and treated depends largely on how it is to be spread, as well as physical limitations of the site.

This decision aid is designed to help you choose the type of effluent collection and handling systems which are suitable for the spreading method you wish to use for your dairy shed effluent.

To start, choose the spreading method you would like to use, then follow the links which provide information on the components of the system which are needed to prepare the effluent for spreading by the method chosen.

When you have decided on the type of system which may suit your dairy, read Guideline Number 4, "Choosing an Effluent Management System" for details on regulations, environmental factors, and fundamentals of the different systems before you make your final decision.

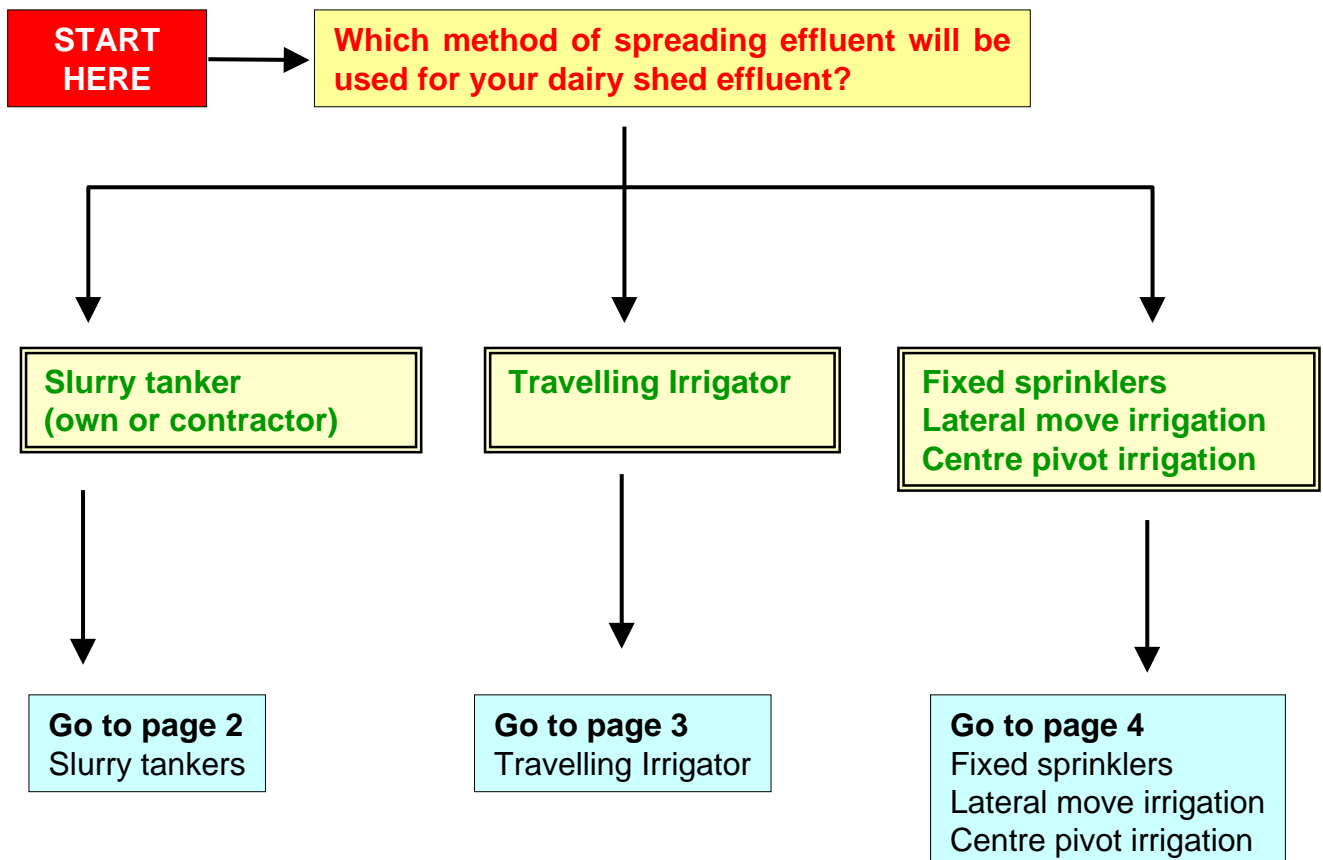

SLURRY TANKERS

Use this page to obtain an outline of a system for collection and treatment of effluent for spreading with slurry tankers

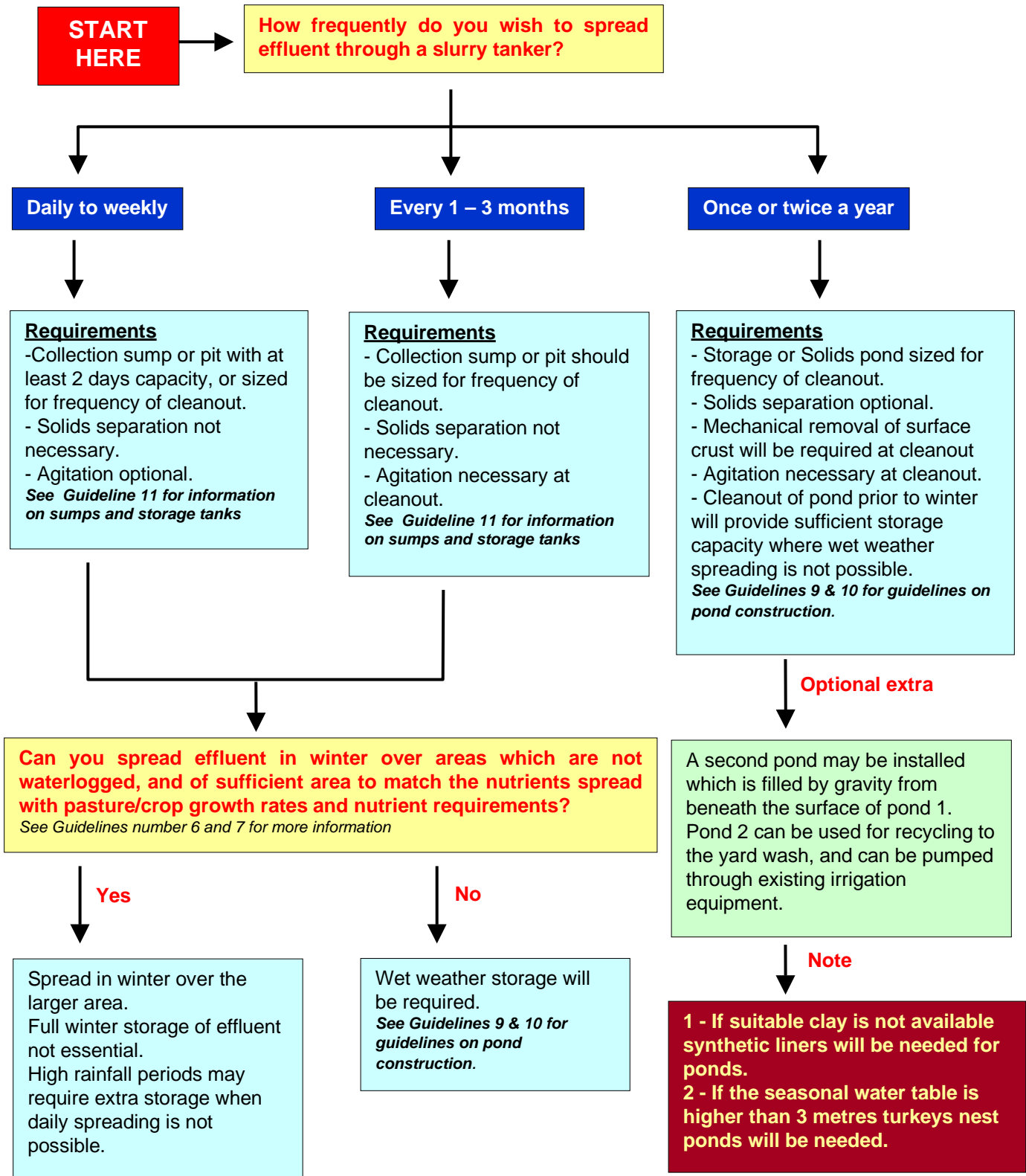

TRAVELLING IRRIGATOR

Use this page to obtain an outline of a system for collection and treatment of effluent for spreading with travelling irrigators.

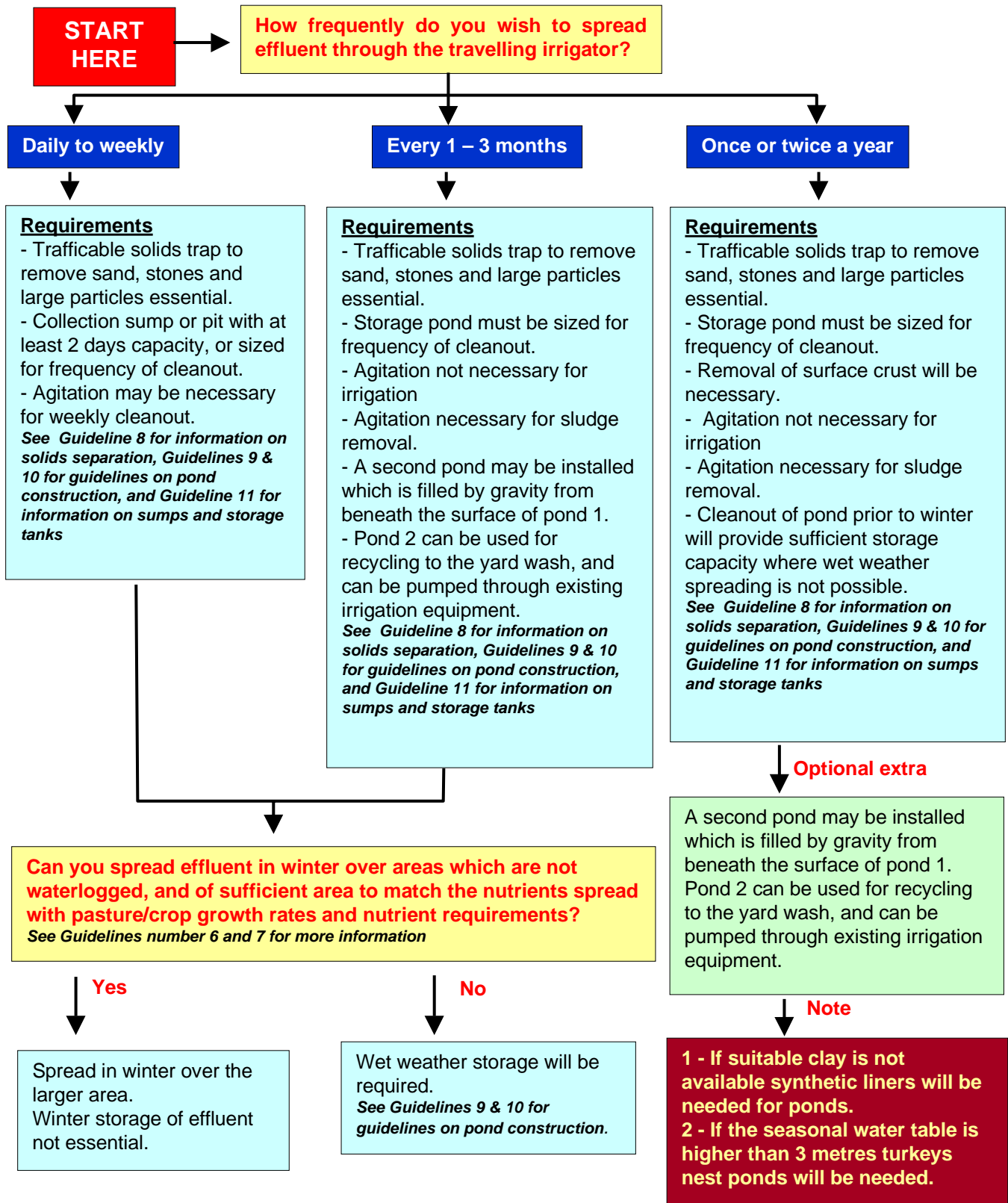

FIXED SPRINKLERS, LATERAL MOVE AND CENTRE PIVOT IRRIGATORS

Use this page to obtain an outline of a system for collection and treatment of effluent for spreading with fixed sprinklers, lateral move and centre pivot irrigation systems.

**START
HERE**

**Separation of solids which are larger than the smallest sprinkler nozzle is essential.
The use of mechanical separators, or gravity separation systems are both suitable.**

Mechanical Separation Requirements

- Trap to remove sand and stones essential.
- Collection sump or pit with at least 2 days capacity.
- Agitation of effluent before separation advisable.
- A short term storage tank or small pond for separated liquid essential.
- Separated effluent can be pumped from storage tank/small pond to irrigation system, or wet weather storage pond when required.

See Guideline 8 for information on solids separation, Guidelines 9 & 10 for guidelines on pond construction, and Guideline 11 for information on sumps and storage tanks

Optional extra

The storage tank for separated liquid can be fitted with a draw off at 1 metre depth and be recycled to yard wash, the sediment can be returned to the collection pit for further processing.

Gravity System – Solids Pond Requirements

- Trap to remove sand and stones recommended.
- Solids pond must be sized for frequency of cleanout, usually 1 – 2 times per year.
- Removal of surface crust will be necessary.
- Agitation will be necessary at cleanout.
- A second pond which is filled by gravity from beneath the surface of pond 1 is essential.
- Pond 2 should be sized to provide wet weather storage capacity.
- Pond 2 can be used for recycling to the yard wash, and can be pumped through existing irrigation equipment.
- Cleanout of both ponds prior to winter will provide sufficient storage capacity where wet weather spreading is not possible.
- Note: If suitable clay is not available synthetic liners will be needed for ponds.
- If the seasonal water table is higher than 3 metres turkeys nest ponds will be needed.

See Guideline 8 for information on solids separation, Guidelines 9 & 10 for guidelines on pond construction, and Guideline 11 for information on sumps and storage tanks

Can you spread effluent in winter over areas which are not waterlogged, and of sufficient area to match the nutrients spread with pasture/crop growth rates and nutrient requirements?

See Guidelines number 6 and 7 for more information

Yes

Spread in winter over the larger area.
Winter storage of effluent not essential.

No

Wet weather storage will be required.
See Guidelines 9 & 10 for guidelines on pond construction.

Why Should I Install an Effluent Management System?

Guideline No 1.



There are four main reasons that you need to consider when contemplating why you should install an Effluent Management System.

- *Benefits of Using Dairy Effluent as a Fertiliser*
- *Taking on Your Environmental Responsibility*
- *Creating a Positive Environmental Image of the Dairy Industry*
- *The Environment Protection (Water Quality) Policy 2003*

Benefits of Using Dairy Effluent as a Fertiliser

Dairy effluent is a valuable resource as it contains nutrients, which are needed for growth by pastures and crops. The major nutrients of value in dairy effluent are Nitrogen (N), Phosphorus (P) and Potassium (K). The amounts of major nutrients in the effluent leaving the dairy shed depends on the time the cows spend at the dairy shed and their behaviour.

For every 100 milkers effluent worth between \$2,500 and \$2,700 fertiliser equivalent could be captured at the dairy.

This alone is a compelling reason to collect and utilise the effluent from the dairy shed.

An effluent management system could cost between \$150 and \$350 per cow to install. Actual cost will depend on the type of system installed, whether the system requires a high level of user labour input (generally cheaper to install but more costly to run) or a more automated system which requires minimal labour input from the operator (more expensive to install but generally cheaper to operate).

A system for 100 cows could cost approximately \$25,000, which would have a pay-back period of less than 10 years based on the value of major nutrients in the effluent captured alone.

An added bonus is the effluent can be used to value-add summer crops through irrigation systems or grow extra pasture for milkers. Winter pastures will receive a boost from effluent applied in the late autumn. Studies in New Zealand have shown an increase of 50% in pasture growth following the spreading of effluent.

It is best to apply effluent when pasture or crops are actively growing so that they can utilise the nutrients. In the most regions of South Australia, the end of spring and then soon after the autumn break are ideal times. Often a single irrigation to a fodder crop at this time of the season will make a big difference in yield. The extra production from crops and pastures irrigated at this time will help to shorten the "payback" time.

Taking on Your Environmental Responsibility

Every person has a responsibility not to harm the environment. All reasonable and practicable measures must be taken to prevent or minimise environmental harm caused by any activity.

Dairy shed effluent has the potential to cause harm or degrade soil, and ground and surface water resources. For example, studies in the South East have shown that Nitrate – N levels in groundwater in some areas already exceed the drinking water guidelines set by the National Health and Medical Research Council. Dairy farms have been identified as a major contributor to the N levels in the groundwater.

To prevent degradation of soils and water resources, nutrients in effluent can be recycled by growing crops or pastures. In this way the nutrients, particularly the major nutrients nitrogen, phosphorus and potassium, can be captured in the root zone. Nutrients constantly applied in excess of plant requirements either build up in the soil until the physical and chemical properties of the soil are degraded, or the soluble nutrients move below the root zone and are no longer available to plants. In some regions these will eventually end up in groundwater.

Creating a Positive Environmental Image of the Dairy Industry

Quality assurance schemes for milk quality have been implemented in the industry over the past few years. These schemes are designed to ensure the safety of the milk and the milk products produced. It can also be used to demonstrate good milk production, harvesting and processing practices to the whole milk marketing chain. However, they do not encompass environmental issues such as the design and operation of effluent management systems.

The general public perceives dairy farmers, rightly or wrongly, as contributing to environmental pollution through ineffective management of their effluent. For example, a study in the South East in 1998 showed that dairy production resulted in the highest maximum levels of nitrate in groundwater and therefore concluded that past and current management practices are contributing to the degradation of the groundwater resource. Clearly, from this work and the public perception, the dairy industry needs to adopt sound effluent management practices and demonstrate its commitment to the protection of the environment.

Many industries are now adopting the Environment Management Systems (EMS) approach to demonstrate their environmental responsibility. Retailers are beginning to demand EMS certification of products as a condition of purchase. Without the certification there is no market for the product. For many it has become not a question of “What premium is in it for me?” but “What do I have to do to remain in the market place?”.

The image of dairy farmers as seen by the general public needs to be improved. The adoption of sound effluent management practices will be a step towards improving this image.

The Environment Protection (Water Quality) Policy 2003

Not only is it a good idea to manage and use the nutrients in effluent, it is mandatory for all dairies to have an effective effluent management system. The Environment Protection (Water Quality) Policy sets out the mandatory requirements.

The *Environment Protection (Water Quality) Policy 2003* is a legislative tool provided for by the *Environment Protection Act 1993* to address the protection of waters in South Australia.

The Environment Protection (Water Quality) Policy 2003 clarifies the obligation imposed by section 25 of the Act (General Environmental Duty) on any person in South Australia undertaking an activity that pollutes or might pollute in relation to impacts upon water quality. The policy establishes water quality framework objectives and sets down general obligations. These obligations include avoiding discharge to water; to not contravene the water quality criteria set down in the policy and to not cause certain environmental harm.

As a Dairy Farmer, how does the Environment Protection (Water Quality) Policy Relate to me?

The Environment Protection (Water Quality) Policy includes general obligations not to discharge pollutants into waters and not to cause environmental harm. It also contains a section, which relates specifically to wastewater lagoons and dairy milking sheds. Relevant extracts from these two sections are:-

Wastewater storage lagoons

18. (1) construction of wastewater storage lagoons should be avoided in the following locations:

- (a) any flood plain that is subject to flooding that occurs, on average, more often than once in every 100 years;
- (c) within 20 metres of a public road or road reserve;
- (d) within 50 metres of a bank of a watercourse;
- (e) within 200 metres of a residence built on land that is owned by some other person;
- (f) within 500 metres of the high water mark;
- (g) within an area where the base of the lagoon would be below any seasonal water table.

Mandatory provision: Category B offence.

(3) A person who constructs a wastewater storage lagoon must comply with the following provisions:

- (a) the lagoon must be constructed so that polluted water in the lagoon cannot intercept any underlying seasonal water table; and
- (c) ...the lagoon must be constructed of or lined with a barrier that minimises, as far as practicable, leakage from the lagoon;
- (d) a sufficient number of monitoring bores must be installed and properly placed so that the presence of any leakage can be readily ascertained;
- (e) the lagoon must be constructed so as not to be liable to inundation or damage from flood waters;
- (f) if there is any potential for the wastewater in the lagoon being a risk to the health of any animals, sufficient barriers to access to the lagoon by those animals must be installed.

Mandatory provision: Category B offence

(4) A person must ensure that the lagoon is maintained in a condition that ensures ongoing compliance with the provisions set out.

Mandatory provision: Category B offence.

(5) A person who discharges wastewater into a wastewater storage lagoon must not allow the water in the lagoon to reach a level that is less than 600 millimetres from the level of the maximum carrying capacity of the lagoon.

Mandatory provision: Category B offence.

Milking sheds

28. (1) In this clause—

"milking shed" means any structure, whether roofed or not, at which operations for the milking of animals are carried on, including any associated yard areas in which animals are confined prior to or following milking.

(2) An operator of a milking shed must ensure that—

- (a) the premises incorporate a wastewater management system; and
- (b) the system is effectively operating in respect of any wastewater generated at the premises while the premises are being used as a milking shed; and
- (c) waste generated at the premises is not discharged—
 - (i) into any waters; or
 - (ii) onto land in a place from which it is reasonably likely to enter any waters (including by processes such as seepage or infiltration or carriage by wind, rain, sea spray or storm water or by the rising of the water table).

Mandatory provision: Category B offence.

- (3) If a person operates a milking shed, the code titled *Code of Practice for Milking Shed Effluent 2003 (CoP)* prepared by the Authority applies.
- (4) The Authority may issue an environment protection order to a person who operates a milking shed to give effect to the code referred to in subclause (3).

How does the Water Quality Policy link to the Code of Practice and Guidelines?

An important feature of the *Environment Protection (Water Quality) 2003*, is the link between the policy, the Code of Practice for Milking Shed Effluent and the Dairy Effluent Guidelines. These Dairy Effluent guidelines are intended to provide information to assist dairy farmers to select and operate a system which complies with their legal obligations under the *Environment Protection (Water Quality) Policy 2003*. The Code of Practice for Milking Shed Effluent outlines the general outcomes required for a dairy effluent system.

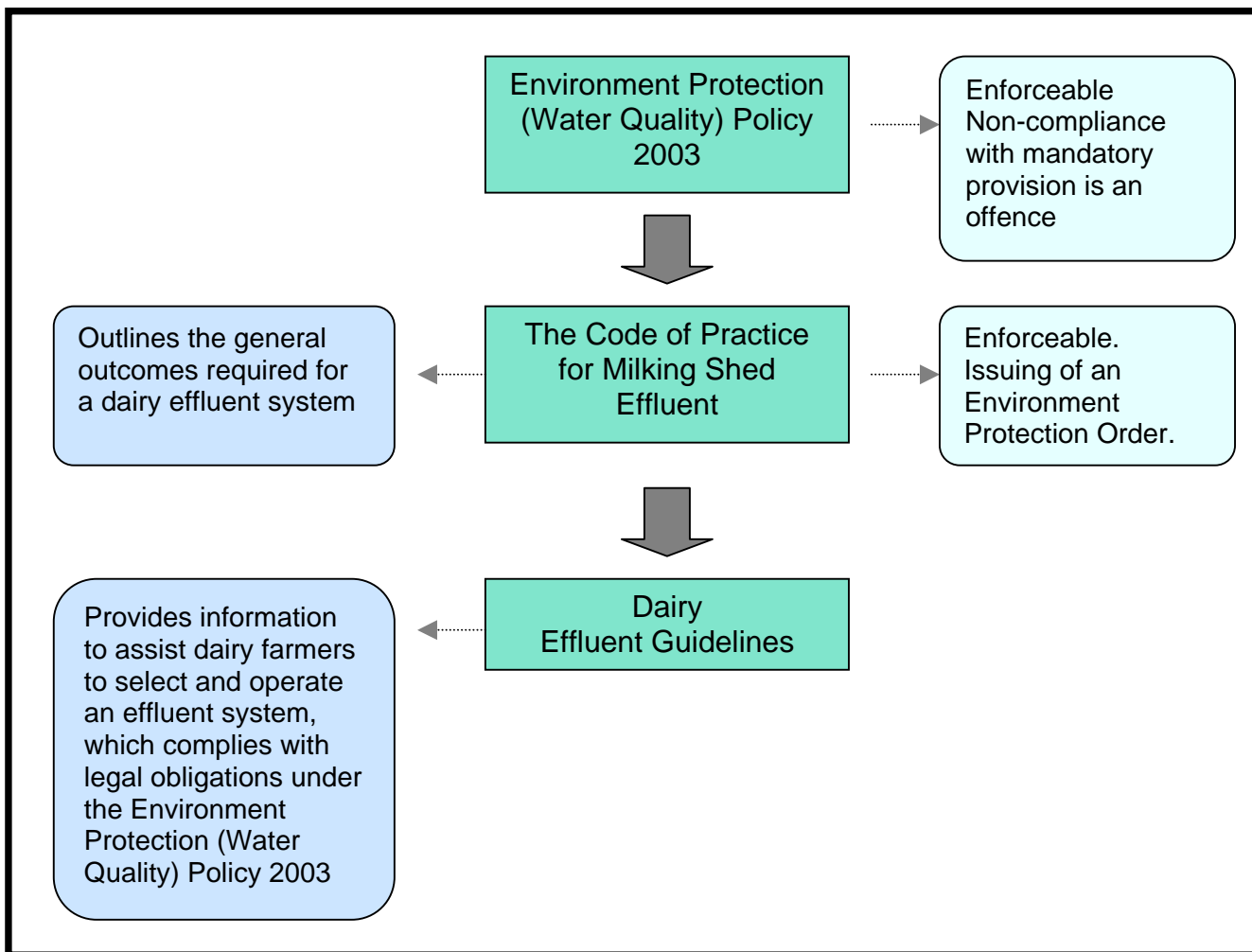

Flow chart depicting the relationship between the Environment Protection (water quality) Policy 2003, Code of Practice for Milking Shed Effluent and the Dairy Effluent Guidelines

The Environment Protection (Water Quality) Policy 2003 uses the Code of Practice for Milking Shed Effluent and the Dairy Effluent Guidelines as a means of describing how a person undertaking a particular activity can comply with their general environmental duty. Failure to comply with the code listed in the policy is not an offence; however compliance with specific requirements of a code can be enforced through the issuing of an Environment Protection Order (EPO).

The Code of Practice of Milking Shed Effluent 2003

The specific requirements of the Code of Practice of Milking Shed Effluent describes what a person undertaking a particular activity must or must not do in order to comply with the requirements of the Environment Protection (Water Quality) Policy 2003 and the Act generally. These specific requirements are usually outcome based and not prescriptive. For example, the policy states that a person responsible for a milking shed must not dispose of dairy waste into a watercourse. The Milking Shed Code of Practice may provide a number of options for alternative means of disposal. There may be many ways how the disposal can occur and therefore it may not be appropriate to specify a particular way, so long as the outcome is achieved.

The Code of Practice of Milking Shed Effluent provides advice and information on how a person undertaking a particular activity can meet the specific requirements and operate in a

best environmental practice manner. This may include, for example, advice on how to treat wastewater, with a description of different options that could be used.

Using the advice provided in the Code of Practice should ensure that the specific requirements are met. It is recognised that there may be instances where alternative approaches can be used to the same effect or that circumstances may dictate that a higher level of care is required. For this reason, the advisory sections of a code or guideline are not intended to be enforceable provided the outcome is achieved.

What happens if for some reason I don't comply?

The Environment Protection (Water Quality) Policy 2003 sets out specific obligations and requirements that must be complied with as mandatory provisions and may be enforced on people and businesses by authorised officers in several ways:

- issuing an Environment Protection Order (EPO) to gain compliance with the policy
- issuing an expiation notice (\$300) for a breach of a mandatory policy
- issuing an EPO and also issuing an expiation notice for a breach of a mandatory policy
- failure to comply with an EPO, by issuing an expiation notice
- prosecution through the Court (maximum penalty \$30,000).

An EPO may require that a person or agency take specified action within a determined time period. Authorised officers under the policy include the Environment Protection Authority, local councils and other regional government authorities.

Non-compliance with a mandatory provision is an offence. Depending on the seriousness of the offence, the EPA may choose to prosecute through the court or take other options as listed above. Fines may apply if you have been shown to be negligent, even if the offence was accidental.

Typically, the Code of Practice for Milking Shed Effluent or Dairy Effluent Guidelines listed in the Environment Protection (Water Quality) Policy 2003, contain specific requirements, advice, and information. The Code of Practice for Milking Shed Effluent or Dairy Effluent Guidelines will not contain offence provisions.

Summary

Installing an effluent management system on your dairy farm will save you a considerable amount of money in fertilisers each year. It is possible that the set-up costs and running costs could be covered by the savings in fertiliser purchase within ten years. The value of extra fodder grown by using effluent could shorten this payback time further. However, if this is not enough incentive to get you started, think of your environmental responsibility and the protection of the soil and water quality in the <Region> for future generations.

The final significant incentive to install an effluent management system comes from the Environment Protection Authority. The EPA through the Environment Protection (Water Quality) Policy will have no option but to enforce the adoption of approved effluent management systems by the issuing of Environment Protection Orders (EPO) and expiation notices on dairy farmers who fail to adopt approved effluent management on their farms.

The Purpose of the Guidelines

Guideline No 2.



- The guidelines provide practical advice on how to set up and manage an effluent system on your dairy farm so that it meets the outcomes and standards required under environmental legislation.
- The guidelines link into the nationally accepted waste management hierarchy.
- The guidelines help you to preserve our natural resources.
- The guidelines are part of a program of assistance to help dairyfarmers choose an effluent management system which suits their circumstances.

Provide Practical Information

These guidelines are intended to provide practical information on how to meet your obligations under the *Environment Protection Act (1993)* (the Act).

The Act and instruments under the act such as the *Environment Protection (Water Quality) Policy 2003*, and the *Code of Practice for Milking Shed Effluent 2003* specify required outcomes or standards which must be met by all dairies. They do not, however, provide information on how you can attain these outcomes or standards.

The purpose of these guidelines is to provide information and options which will help you meet these outcomes or standards.

Waste Management Hierarchy

The waste management hierarchy sets out the preferred order of waste management practices from most preferred (avoidance) to least preferred (disposal). These are:

- **AVOID** producing the waste in the first place
- **REDUCE** the amount of waste produced (more efficient processes)
- **REUSE** any waste that is produced (reuse without re-processing)
- **RECYCLE** any waste that is produced (re-process to create new product)
- **RECOVERY** of waste to create energy
- **TREAT** the waste in a suitable way
- **DISPOSE** of the waste in a suitable way.

Clearly dairies are unable to avoid the production of wastes at the dairy, and the management of the wastes will entail some of the options listed in the hierarchy.

These guidelines link into the waste management hierarchy by providing information which will enable dairyfarmers to

- **REDUCE** the amount of waste by reducing water use, and implementing recycling systems
- **REUSE** the waste by applying it to crops or pastures as fertiliser
- **TREAT** the wastes produced to reduce nutrient levels or pathogen levels.

This will enable dairyfarmers to meet their environmental responsibilities and operate their effluent management systems in accord with accepted water management hierarchy principles.

Preserving Natural Resources

The soil and water resources of South Australia are very valuable. Our agricultural industries and prosperity are highly dependent upon their health, and our existence depends on maintaining the health of our groundwater and surface water resources.

One of the long-term aims of sustainable land and water resource management is the development and adoption of better management practices by rural industries so that soil and water pollution is prevented.

Our childrens' future is worth more than our short term complacency

It is illegal to pollute soil, groundwater or surface water and measures must be taken by the dairy industry to ensure that its activities do not cause pollution. Individual farmers are responsible for preventing pollution on their properties and they may be liable for any pollution that may occur.

So what are these guidelines all about and how are they going to impact on me?

These guidelines are part of a program which has been set up to assist dairy farmers to decide on the most effective waste management system for their property and to implement management practices which will minimise the potential for soil and water pollution. They are an update of the first guidelines which were released over 10 years ago and reflect the requirements of new legislation and codes of practice. The revised guidelines also contain new and up-to-date information on dairy shed waste management.

All dairy farmers must have an effluent/waste water management system installed at their dairies. Those dairies which fail to meet these requirements may have an environment protection order (EPO) placed on them to carry out certain works, or be prosecuted, depending on the pollution problems that they are causing.

Aims of the Dairy Effluent Guidelines

The Guidelines are a tool to enable dairy producers to select, design and implement an effluent management system which is most suitable for their particular circumstances.

Objectives

The principle objectives of these Guidelines are:

- -To demonstrate the financial and environmental benefits of correct effluent management
- -To indicate the minimum standards required to be met in order to minimise groundwater contamination
- -To provide information on the advantages, disadvantages and labour requirements of different types of effluent management systems
- -To provide the specifications and indicative costs for the components of effluent management systems
- -To provide information on management strategies that can be used to minimise the workload required for good effluent management

The Dairy Effluent Guidelines concentrate on the management of dairy shed wastes. While it is recognised that there are other potential sources of soil and water pollution such as silage leachate, farm tracks, disposal of mortalities and intensive feeding or high intensity stocking practices they are beyond the scope of these guidelines. These guidelines will not address in detail the potential pollution arising from these sources.

What support will I have to implement the Guidelines?

The Dairy Effluent Guidelines, together with newsletters, demonstration sites and field days seek to provide dairy farmers with sufficient information so that they can make decisions on which effluent management systems would best suit their particular circumstances. The final decisions on which choices to make lie with each individual farmer and the Guidelines should be used in conjunction with this other information to help make these decisions.

The Guidelines will provide information on a number of effluent management systems and the conditions to which they are most suited. If these systems are effectively installed and managed correctly, they should reduce the risk of pollution to water resources, and farmers should meet their obligations under the Environment Protection (Water Quality) Policy 2003 and the Code of Practice for Milking Shed Effluent 2003.

However, whichever system you install, there will be some time and effort required to operate and maintain the system. These Guidelines contain improved management practices that will help to reduce the time required to operate and maintain the system. These include reducing the amount of water used in washing down the yard and installing storage tanks so that effluent can be recycled. Good planning and design can considerably reduce the amount of time and effort required for effluent management.

The Dairy Effluent Guidelines have been prepared as a series of "fact sheets". This allows the most up-to-date information to be incorporated quickly and easily. Information is therefore easy to find and it allows relevant information from other sources in Australia to be included.

An Excel spreadsheet model has been produced to help dairy farmers check whether their effluent spreading programme is sustainable. Sustainability is based on the mass balance of Nitrogen, Phosphorus and Potassium removed in produce with that added in effluent. To run the model for your farm contact the Dairy Effluent Management Technical Officer for the project on 08 8842 6222, your Dairy Company Field Officer, or the EPA.

Requirements of an Effluent Management System

Guideline No 3.



Your dairy effluent management system must be capable of managing all of the effluent generated at the dairy shed and yards. It must do this in such a way that it does not degrade the soil or water resources and does not leave the property of origin.

To ensure that these requirements are met, you also need to consider the following:-

- *How the effluent is stored*
- *How to manage effluent in winter*
- *Installation of a back-up plan*
- *Effectively manage the nutrients in effluent*

An effluent management system must be capable of managing all the effluent generated at the dairy shed and yards and must ensure that:

- All effluent is managed in such a way that soil or water resources are not degraded.
- Effluent does not leave the property of origin.

To ensure this, there are a number of fundamental requirements that the effluent management system must meet.

What are the Requirements of an Effluent Management System?

All effluent from the dairy and holding yards must be collected at the dairy. This may occur in a sump from which the effluent is pumped or transported direct to pasture or the effluent may be transferred to a pond storage or treatment system for later spreading. Irrigation from ponds may provide better flexibility. If a two pond system is used the effluent from the second pond may be re-used to wash the dairy yards.

Taking into account Cold and Wet Winters

Pumping effluent direct to pasture is only an option at times of the year when pasture is actively growing and pasture water use is greater than effective rainfall. Some form of storage will be required for dairy shed effluent produced during the “winter” period when effective rainfall exceeds evaporation, or pasture growth is suppressed by low soil temperatures. For more information on effective rainfall and evaporation in your district refer to **Guideline No 6 – Rainfall and Evaporation**. For more information on temperatures as they affect pasture growth in your district refer to **Guideline No 7 – Temperature and Pasture Growth**.

Effluent stored in the pond system over the winter period is best spread on pasture during spring and summer to maximise the use of the nutrients it contains. Also the storage pond level should be drawn down before the winter period each year to a level which enables the pond to store the effluent generated in the following winter period.

In the ponds, a minimum freeboard of 600 millimetres from the designed top water level to the spillway must be maintained as a buffer for storm events and other unforeseen circumstances.

Have a Back-Up System

Back-up systems must be in place in the event that there is a pump breakdown. This may be a spare pump, or access to a manure tanker. Another option may be holding tanks sufficient for at least two days peak storage. Such back-up holding tanks must not be used on a day-to-day basis, otherwise they will probably not be available in an emergency. For more information, refer to ***Guideline No 18 – Emergency Backup Plans***.

Clay Lined Ponds

Effluent ponds that have been lined with imported clay may dry out and crack if completely emptied and the clay exposed, which will allow the pond to leak. The clay liner can be protected with a layer of crushed rock or some effluent may be retained to ensure the liner remains wet. The amount of effluent held back to protect the liner must be allowed for when calculating the size of the effluent pond.

Similarly, the pond should be over-excavated to allow for the depth of the clay liner – a depth of 450 millimetres is recommended for ponds over 2 metres deep – plus the depth of any protective crushed rock overlay.

Managing the Nutrient Levels in the Effluent

Effluent should be spread on pastures at rates which allow the pasture to utilise the nutrients it contains. Excess applications of nutrients can result in soil degradation, surface runoff of nutrients, or leaching below the root zone and into groundwater.

The pasture or crops grown from applied effluent should be utilised to their maximum to remove as much of the pasture and the nutrients applied in the effluent as possible. This will minimise the area required for spreading the effluent by maximising the removal of nutrients from the area.

A nutrient budget for the effluent utilisation area should be used to balance the nutrient inputs with the amounts removed from the area. Nutrient inputs will include those in the effluent, in any solid manure spread on a specified area, as well as nutrients from fertilisers that have been applied. Nutrients removed will include milk produced from the area, silage or hay harvested from the area, and live weight gain of livestock grazed on the area. Some nitrogen is also lost by grazing cattle in the form of ammonia.

Effluent is not a balanced fertiliser. Application of effluent to meet the most limiting nutrient for pasture utilisation and removal rates may under supply other nutrients. Where milk fever and grass staggers are a likely problem, avoid grazing effluent utilisation areas with springing cows and recently calved cows. On farms with high potassium levels the potassium content of the effluent should be considered when deciding effluent spreading rates.

Dairy shed effluent composition varies between farms and between times of the year. Effluent which is applied directly to pasture should be tested at several times throughout the year. Stored effluent should be tested before spreading. Any laboratory, which carries out soil, plant and fertility analysis should be able to carry out an effluent nutrient analysis.

Soil nutrient testing should be done at least every two years to monitor soil nutrient levels. The results of monitoring can be used to check the build-up of nutrients in the soil that could affect the rates at which effluent can be spread. For more information, refer to ***Guideline No 19 – Monitoring the Effluent Management System***.

Tips on Managing Your Dairy Effluent Management System

Avoid having loose material on races running up to the farm dairy. Wood chips placed on races near the yard area are commonly brought into the dairy by the cows and block the drains, sump inlets and pump.

Over the calving period, watch out for afterbirth entering and blocking the stone trap.

Clean out screens, filters and solid traps regularly. Coarse materials moving through pumps and piping will cause damage and wear.



Regular maintenance of the effluent management system will reduce the number of breakdowns and allow the system to function as planned.

Maintain drains and repair broken or badly laid concrete to prevent effluent from ponding.

Rubberware and ear tags commonly block sumps. A rubbish drum should be placed outside the farm dairy for bags, tubes and other disposable items.

Choosing an Effluent Management System

Guideline No 4



There are many variables that you need to consider when selecting a suitable dairy effluent system for your property.

- *The system must comply with the general obligations as stated in the Environment Protection (Water Quality) Policy 2003.*
- *Observe the restrictions associated with effluent pond placement and the spreading of effluent.*
- *Evaluate the operational and environmental factors on your farm which will influence your choice of effluent system.*
- *Weigh up the advantages and disadvantages associated with each of the available types of dairy effluent systems.*

Choosing an effluent management system that meets the requirements of the Environment Protection Authority, State and Regional Natural Resource Management (NRM) objectives and also suits your own farm circumstances requires some thought and planning.

This guideline outlines the issues which need to be considered in the decision making process and provides references to other guidelines and information which will provide more detailed information to help you make your decision.

What are the Regulatory Issues that I need to Consider?

The Environment Protection (Water Quality) Policy 2003 imposes general obligations for all activities which produce wastes to avoid:

- the discharge of wastes into any waters,
- or onto land from which it is reasonably likely to enter any waters.

Dairy effluent must therefore be managed in such a way that it remains on the farm and it does not contaminate surface water or groundwater resources. This means that the effluent must be managed so that its nutrients can be utilised on the farm and any overflow from the ponds, sprinklers or drains is not allowed to leave the farm. It also means that effluent is not allowed to percolate downward to the water table and into the groundwater.

A wastewater management system is mandatory for all dairies. The system must be operating effectively at all times that the premises is being used as a milking shed.

(Refer to Guideline 21: Legal Requirements and Constraints).

Limitations to Dairy Effluent Pond Location

The following restrictions apply to the location of a dairy effluent pond. A pond used for storage or treatment of dairy shed effluent must not be located:

- Closer than 200 metres to a house not located on the subject land;
- Closer than 20 metres to a public road;
- Where it is likely to be inundated or damaged by water during a flood which has an average recurrence interval of one in 10 years or greater;
- Within the 1956 River Murray Flood Plain.

Solids separation pits should not be located:

- within 50 metres of a house on a neighbouring property
- 25 metres of a water supply bore, sink hole or watercourse
- within a flood plain with a flooding frequency of more than once every 10 years.

Limitations of Spreading Dairy Effluent

Limitations also apply to spreading dairy effluent and solids. Milking shed effluent must not be discharged or allowed to escape onto land within:

- 50 metres of an irrigation drainage channel containing water, or a water course, bore, dam or sink hole;
- 10 metres of a dry irrigation drainage channel;
- 100 metres of a dwelling not on the subject land;
- 10 metres of land not owned by the owner of the milking shed.



Dairy Effluent being spread over pasture, taking in consideration the limitations described above.

Whatever system you choose, it must operate and comply with the requirements of the Environment Protection (Water Quality) Policy 2003. This must also include limitations outlined for pond storage and spreading of effluent.

Choosing Your System

When choosing an effluent system that is appropriate for your needs, you will need to consider operational and environmental factors that will influence your design choice.

To assist you in making this choice, a list of operational and environmental factors has been compiled for you to consider. As you review the following examples, make a list of the environmental factors that have the greatest influence on your property. This will provide you with some guidance in making the correct effluent system choice.

Operational factors that influence effluent system choice

Herd Size

- Plan for the size herd you anticipate milking in the future, eg 20 years time

Effluent Volume

- Measure the amount of water used to wash machines, yards, cups, platform etc.
- Minimise the amount of water entering the effluent system by diverting clean storm water and implementing water saving practices in the dairy (recycle plate cooler water, recycle dairy plant wash water, change hose nozzles, recycle yard wash water).

Land Area for Effluent Utilisation

- Is there sufficient area available for sustainable utilisation of the effluent? Allow at least **one hectare for every 15 cows** milked for initial planning.
- Identify restricted areas, such as nearby houses, waterways such as creeks, drains, swamps and wetlands (whether permanent or seasonal), wells etc.
- Will you be constructing a feed pad that will produce effluent, which will also need to be utilised?

Environmental factors that will influence effluent system choice

Soil Type

- Sandy soils are able to absorb effluent more quickly than loams or clays, but they also let nutrients such as nitrate percolate through more easily into the groundwater. (**Refer to Guideline No 5: Climate and Soils**).
- Effluent should not be spread on any soils that are water-logged.
- Clay soils may be suitable for sealing the effluent ponds.

Climate

- Is there a time of the year when effective rainfall exceeds evaporation? Effluent should not be applied to land at those times, so storage of effluent will be required. (**Refer to Guideline No 6: Rainfall and Evaporation**).

Topography

- Are there suitable sites for ponds?
- Can the effluent be conveyed to the ponds by gravity flow, or are pumps needed?
- Is runoff likely to occur from sloping ground where the effluent will be spread?

Surface Water

- Are there permanent streams, dams and waterways such as creeks, drains, swamps and wetlands (whether permanent or seasonal), or wells, which you must keep away from?
- Do gullies run water during the winter?

Groundwater

- How close to the surface is the permanent groundwater?
- Is the groundwater used for household purposes, stock water, or irrigation – either by yourself or other persons?
- If the soil type readily allows effluent to seep down to the groundwater, care will need to be taken to match the nutrients spread in effluent with crop uptake.

The answers to these questions will provide the basis for the decision on which system will best suit your dairy. For assistance in making this choice or documenting operational and environmental factors, please refer to Guideline No 23, Sources of More Information.

How do I determine what effluent system to use?

Direct Application To Pastures and Crops

Direct application may be used where soils, groundwater levels and topography are suitable. Direct application for part of the year will reduce the size of the ponds required for effluent storage.

Wet weather storage may be required for some period over winter when effective rainfall exceeds evaporation. (**Refer to Guideline 6 : Rainfall and Evaporation**).

Storage may be required at times of the year when soil temperatures are low and significantly depress the growth of crops and pastures. (**Refer to Guideline 7 : Temperature and Pasture Growth**).

Fundamentals of Direct Application to Pasture and Crops

- For small herds spreading can be done with a manure cart
- For larger herds effluent can be applied by sprinkler. This will require a pump. To extend the life of the pump, a solids separation system should be installed to remove the stones and grit.
- Additional capacity in the effluent collection tank should be planned to cater for breakdowns in the spreading equipment
- At times of the year when the pastures are waterlogged, or effective rainfall exceeds evaporation, or soil temperatures restrict plant growth the effluent may need to be pumped to a storage facility

Advantages

- Better use of the nutrients in the effluent
- Ponds may not be required

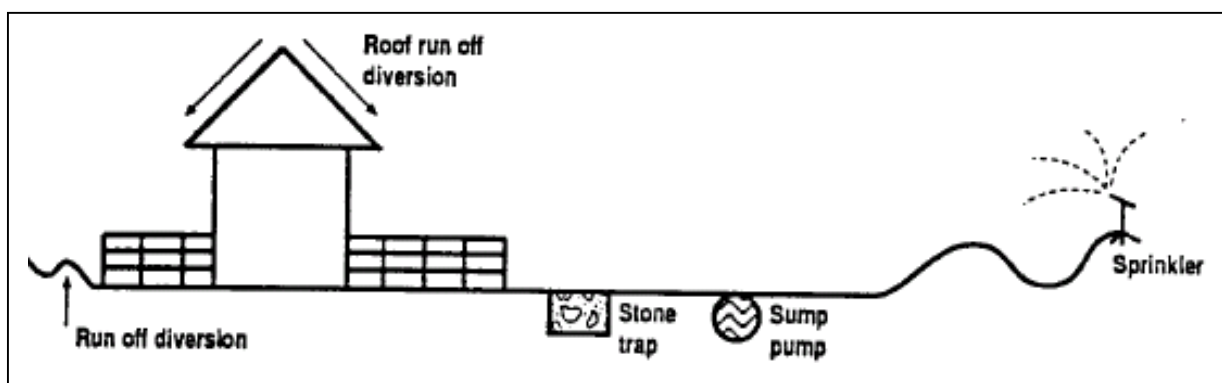

Example of a sump, pump and sprinkler effluent system

(Source: Agriculture Notes: Victoria Agriculture, Dairy Effluent: Applying dairy shed effluent to land.)

Disadvantages

- It is only suitable on well drained soils where surface runoff or deep infiltration are not likely to occur
- Application to waterlogged soils should be avoided. Alternative areas, or larger areas may be required in winter
- Some effluent storage may be required during wet or cold periods
- Careful management is required, as the potential for effluent to move off the property is greater
- The system must be operated over the whole of the milking season
- The need to spell treated paddocks before grazing may interrupt grazing rotations
- Effluent can not be recycled for yard cleaning
- Pumps must be reliable

Single Storage Pond

Fundamentals of the Single Storage Pond System

- Effluent is conveyed to a single storage pond. The effluent is then applied to crops and pastures when the conditions are favourable.
- Solids separation at the dairy yard will reduce the amount of solids and nutrients conveyed to the pond and extend the life of pumps used to convey the yard effluent.
- The single pond may be used as a wet weather storage in conjunction with direct application to pastures and crops. In this instance where the pond only needs to hold wet weather storage it can be smaller than one designed to hold effluent for longer periods.

Advantages

- Effluent can be stored so that it can be applied to pastures and crops when the conditions are favourable. When applied appropriately, this may lead to minimal runoff and minimal leaching to groundwater.
- Irrigation is not needed all year round.
- Workload is shifted to a different time of the year.
- Effluent may be mixed with irrigation water during the irrigation season.

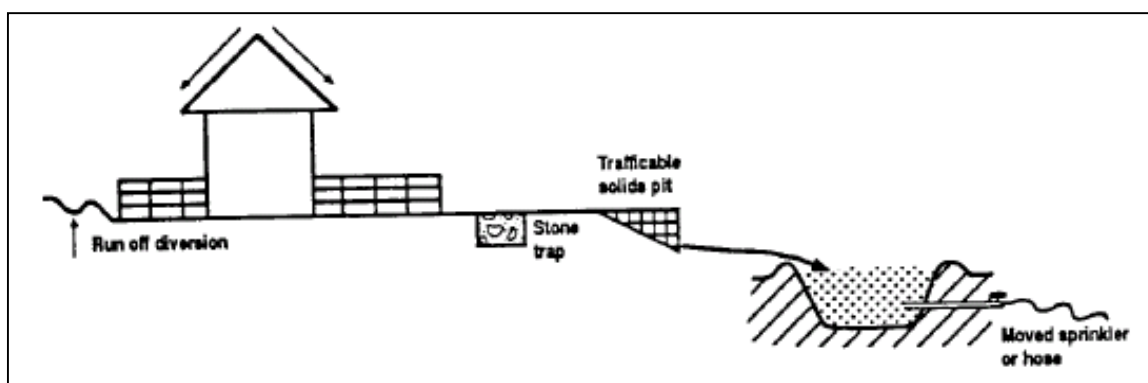

Example of a single storage pond effluent system

(Source: Agriculture Notes: Victoria Agriculture, Dairy Effluent: Applying dairy shed effluent to land.)

Disadvantages

- The pond must be on a site that can be sealed to ensure effluent does not seep into groundwater. Shallow groundwater may require a turkeys nest pond to be constructed.
- Pumps may be required on flat sites, or for turkeys nest ponds.
- Pond contains more solids than the second pond of a two pond system. A special manure pump may be needed.
- Pond needs de-sludging every few years.
- Nutrient content is lower in single ponds than direct application.

Multi-pond Systems

Fundamentals of the Multi-pond System

- Effluent is conveyed to a storage pond where it is allowed to settle for a period of time.
- Overflow from the pond is conveyed into one or more storage ponds.
- Solids separation at the dairy yard will reduce the amount of solids and nutrients conveyed to the first pond and extend the life of pumps used to convey the yard effluent.
- The effluent on the second or subsequent pond will be low in solids and can be re-used in yard washing systems. Recycling effluent can reduce the volume of fresh clean water which is used.

Advantages

- Effluent can be stored so that it can be applied to pastures and crops when the conditions are favourable. When applied appropriately this may lead to minimal runoff and minimal leaching to groundwater.
- Irrigation is not needed all year round.
- Workload is shifted to a different time of the year.
- Effluent may be mixed with irrigation water during the irrigation season.
- Low solids in the second and subsequent ponds means that standard pumps can be used for irrigation and there are fewer problems with blocked pipes.
- Effluent from the second or subsequent ponds may be re-used in yard washing systems, which allows the planned storage capacity to be reduced.

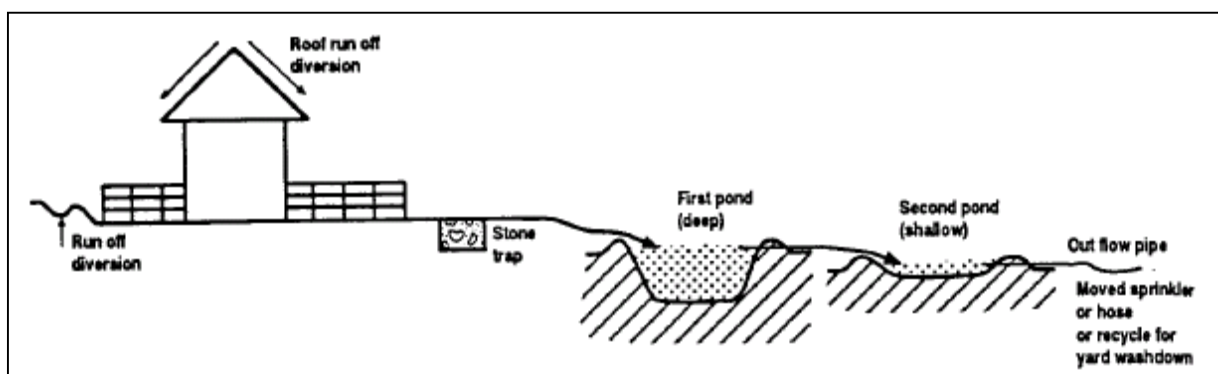

Example of a multiple storage pond effluent system

(Source: Agriculture Notes: Victoria Agriculture, Dairy Effluent: Applying dairy shed effluent to land.)

Disadvantages

- The ponds must be on a site that can be sealed to ensure effluent does not seep into groundwater. Shallow groundwater may require turkeys nest ponds to be constructed.
- Pumps may be required on flat sites, or for turkeys nest ponds.
- Pond contains more solids than the second pond of a two pond system. A special manure pump may be needed.
- The first pond needs de-sludging every few years.
- Nutrient content is lower than direct application.

Using all this information you should be able to choose the type of system which best meets your needs and determine its size and capabilities.

Comparison of different effluent management systems

The following table summarises the different aspects of each effluent system. You will therefore be able to compare the advantages and disadvantages of each system to determine which best suits your needs.

System	Reliability	Wet weather storage	Water recycling	Labour cost	Capital cost
Continuous application					
Sump & gravity flow	Low	None	No	High	Low
Sump, pump & sprinkler	Medium	None	No	High	Medium
Sump & tanker	Medium	None	No	High	High
Ponds					
Single	High	Yes	No	Low	Medium
Double or multiple	High	Yes	Yes	Low	High

Climate and Soils

Guideline No 5.



It is important to know the climate and soils of your property, as it will influence the type of dairy effluent management system that can be implemented.

Times of the year when rainfall exceeds evaporation will identify when spreading of effluent is not advisable and storage of effluent is required.

Soil types will influence the type of lining required in effluent ponds.

Soil type will influence the amount of effluent that can be spread at one time, and the spreading rate.

This Guideline provides a general outline of the regional climate and soils, and how they influence the choice of an effluent management system and the spreading of effluent on crops or pastures.

The Northern and Yorke Agricultural region

The Northern and Yorke Agricultural region is a large and diverse region encompassing the central area of the state. It covers over three million hectares and comprises Yorke Peninsula, the Lower, Mid and Upper North, southern Flinders Ranges and parts of the Adelaide Plains and Barossa Valley.

The Climate of the Region

The region has a Mediterranean climate with mild wet winters and hot dry summers. Conditions vary over the region because of differences in latitude and altitude. Average annual maximum temperatures are around 22°C for the region. Average daily minimum temperatures range around nine to 13 °C. Temperatures often exceed 30°C and on extreme days can reach the mid 40°C.

Rainfall varies from less than 200mm annually in the section north east of Peterborough, to above 600mm in the Clare region and in parts of the southern Flinders Ranges.

The following charts from a number of locations through the region show the amount of evaporation that occurs in relation to the amount of rainfall that occurs in a 12 month period.

The charts show possible times of the year when rainfall exceeds evaporation and storage of effluent may be required. More detail and additional locations can be found in **Guideline 6 – Rainfall and Evaporation**.

Laura
Mean Monthly Rainfall and Evaporation

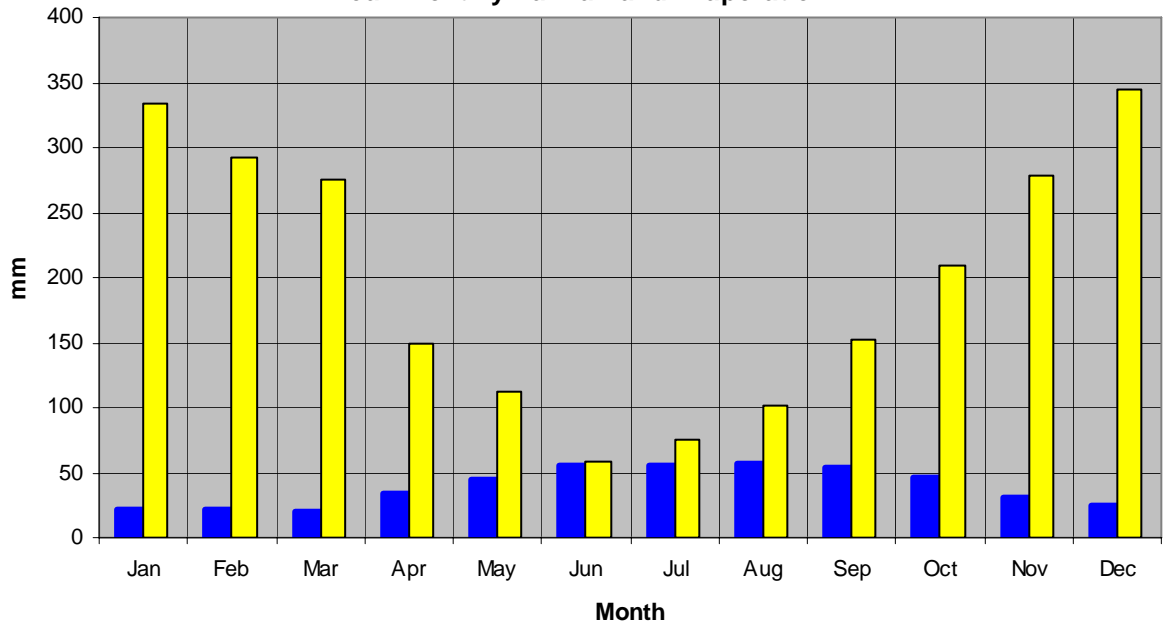

Clare
Mean Monthly Rainfall and Evaporation

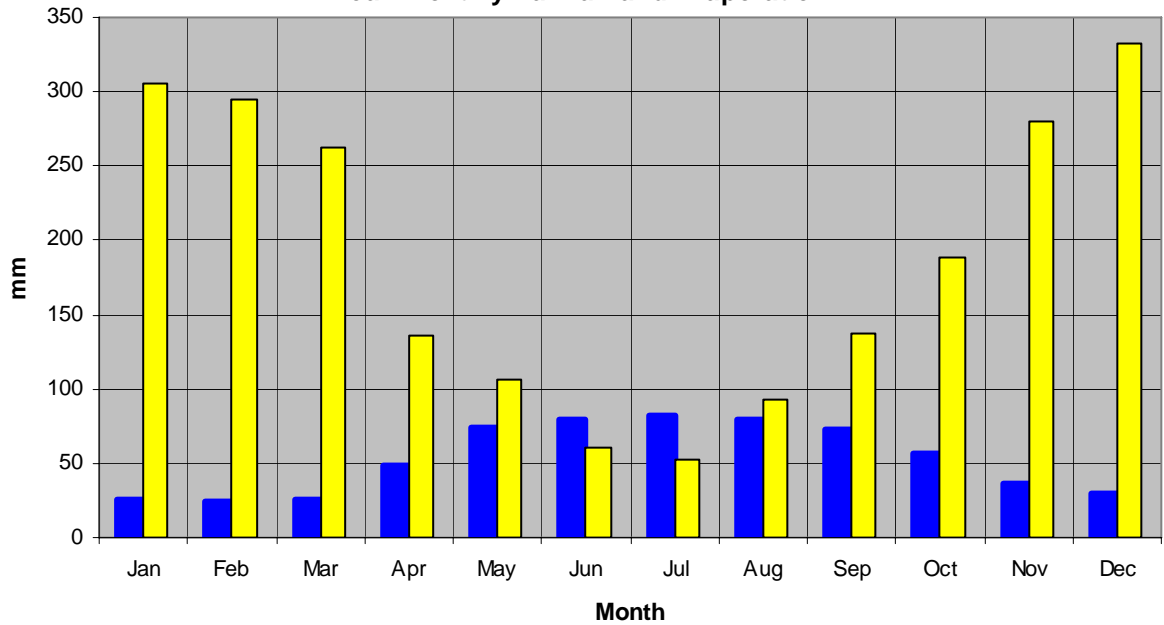

Kapunda
Mean Monthly Rainfall and Evaporation

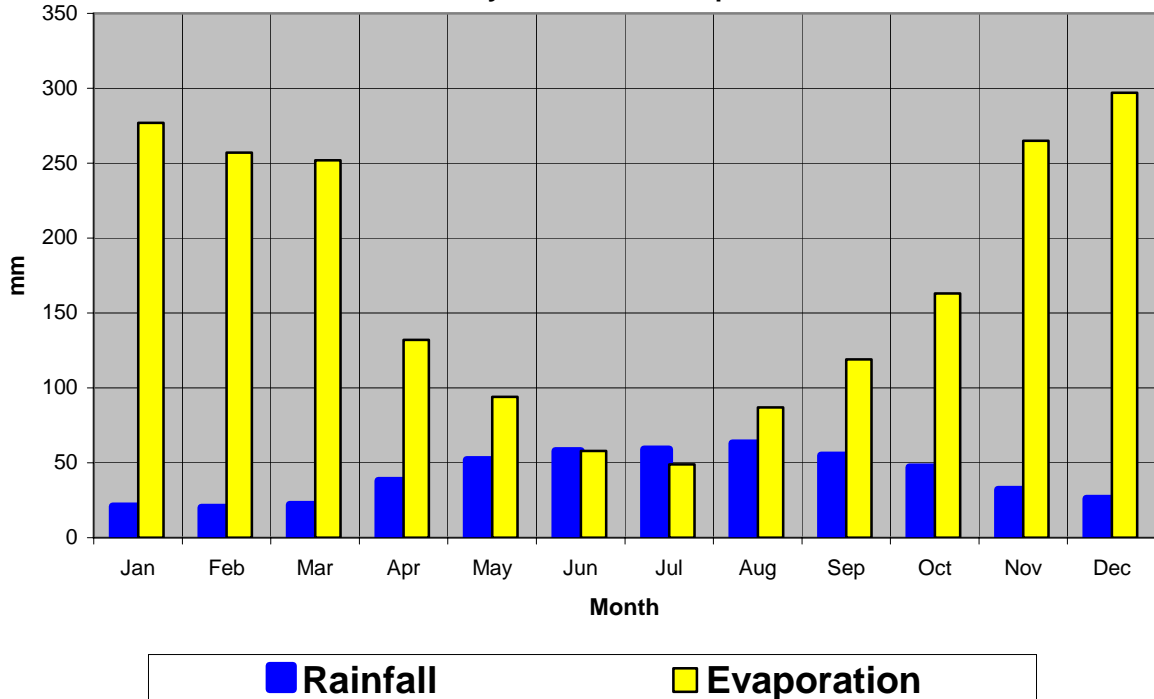

Mallala
Mean Monthly Rainfall and Evaporation

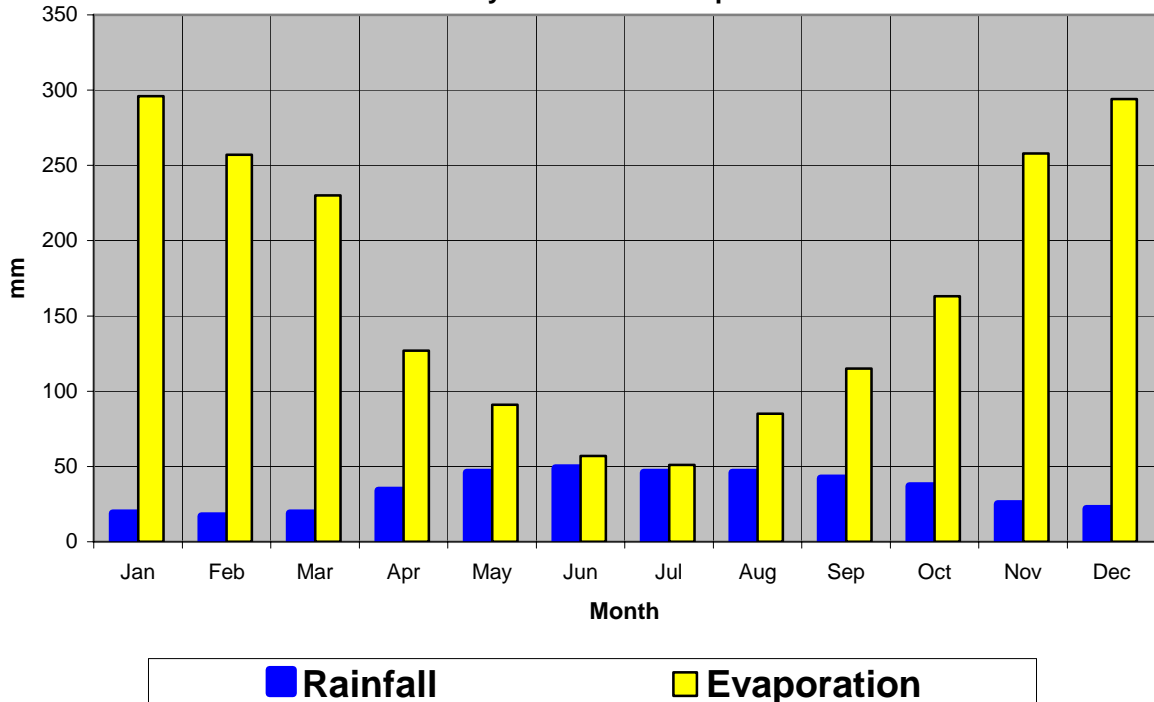

The charts show a period during winter at Clare and Kapunda in which rainfall exceeds evaporation. It is during this time that in normal years pasture growth is not limited by soil moisture, soils are generally wet, and the spreading of effluent from dairy sheds is not

advised. Storage of effluent during this period may be required – a pond for winter storage of effluent should be factored into the effluent management system.

More details of the variation and the time periods when irrigation of effluent is not advised, can be found in *Guideline No. 6: Rainfall and Evaporation*.

Soils in the Northern and Yorke Agricultural region

The soils contribute enormously to the region's environmental, economic and social prosperity. They underpin the primary industries. Soil type and soil properties often are reflected by the type and form of native vegetation that grows in the area.

On the plains and gentle rises west of the Northern Mount Lofty and southern Flinders Ranges are generally calcareous soils formed on calcrete or soft rubbly calcareous sediments. These are usually loams or sands and on Yorke Peninsula often overlie calcrete or limestone.

Deep sands are found on the south west end of Yorke Peninsula, and in dunes of dune-swale systems near Moonta, Avon, east of Grace Plains, north of Balaklava and from Bute to Wandearah. Sand deposits of the coastal and marine zone are a limited and dynamic resource.

The series of ranges that comprise the southern Flinders and Northern Mount Lofty Ranges usually have skeletal soils on tops of hills and hard red-brown texture contrast soils (typically loam over clay) with highly calcareous lower subsoils on slopes. Some of these soils are also found around Petersville and Sandilands on Yorke Peninsula. These soils are formed on basement rock. The soils on the valley floors and plains between the ranges are formed on outwash sediments from the basement rock. They tend to be deep texture contrast soils with calcareous subsoils, deep calcareous soils or gradational/clayey soils with calcareous subsoil.

Effect of Soil Type on Pond Sealing

It is important to know the type of soil you are dealing with in order to determine what effluent management system to implement. If your area has little or no clay, you will have to look at lining your pond with imported clay or an artificial liner. If you do have a clay soil or plan to use imported clay, it must be tested to ensure that it will hold water. All ponds must be sealed watertight.

Effect of Soil Type on Effluent Spreading

The spreading and utilization of dairy effluent by crops or pastures is influenced by soil type. Sandy soils have a higher infiltration rate than clay soils and have a higher risk of passing nutrients below the root zone of the crop. Clay soils on the other hand will cause surface runoff of applied effluent at lower application rates than sandy soils, because the applied effluent is more easily able to soak into the sandy soils.

Soil type therefore can influence the amount (maximum mm per application) and the rate (maximum mm per hour) at which effluent can be applied.

It is important to recognize the soil types on your property and apply effluent according to soil water holding and infiltration characteristics.

Slope will also affect infiltration rate. Steeper slopes generally cause greater surface runoff and need lower application rates (mm per hour) to prevent this happening.

The table shows general data for different basic soil types.

Table – Typical Water Holding Capacity, Infiltration and Application Rates

Soil Type	Available Water Holding Capacity (mm/m)	Infiltration Rate (mm/hr)	Irrigation Application rate (mm/hr)#		
			0 – 5% slope	5 – 10% slope	Over 10% slope
Coarse and fine textured sands, and loamy sands	20 – 60	12 – 25	10 - 20	8 - 16	5 – 10
Moderately coarse textured sandy loams, loam, sandy clay loams and silt loams	80 – 130	9 – 20	8 – 16	6 – 11	4 - 8
Medium textured very fine sandy loams, loam, sandy clay loams and silt loams	130 – 160	5 – 8	4 - 6	3 – 5	3 – 4
Fine textured sandy clays, silty clay, and clay	Silty clay 130 - 160 Clay 160 – 250	1 - 4	Less than 4	Less than 3	Less than 3

Application rates are for bare ground. Rates may be increased with good plant cover.

Map of Soil Types in the Northern and Yorke Agricultural region

The soil map below provides an overview of the many soil groups across the Northern and Yorke Agricultural region.

Before installing an effluent management system, it is important to obtain more detailed information on the soil types in your region. Soil tests should also be conducted on the suitability of the soil for pond construction. Soils are probably the most variable aspect of your farm.

Maps can provide a general overview of the soil type and its properties but only a detailed investigation of the soil properties will provide all the right details for the installation of a system that will hold water.





Government of South Australia
Northern and Yorke Natural
Resources Management Board

Northern and Yorke NRM Region SOIL GROUPS

The map depicts the distribution of up to 15 generalised soil groups. The map is based on an interpretation of soil landscape units. Soil landscapes invariably comprise several soils. The most commonly occurring soil group in each landscape is delineated on this map.

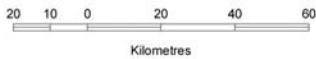
-  Calcareous soils
-  Shallow soils on calcrete or limestone
-  Gradational soils with highly calcareous lower subsoil
-  Hard red-brown texture contrast soils with alkaline subsoil
-  Cracking clay soils
-  Deep loamy texture contrast soils with brown or dark subsoil
-  Sand over clay soils
-  Deep sands
-  Highly leached sands
-  Ironstone soils
-  Shallow to moderately deep acidic soils on rock
-  Shallow soils on rock
-  Deep uniform to gradational soils
-  Wet soils
-  Rock
-  Water
-  Not applicable or no data



-  Northern and Yorke NRM Region Boundary
-  Main Roads

NOTES ON USE OF THE MAP:

1. This information is derived from limited field inspection, and is subject to change without notice.
2. Boundaries between mapping units should be treated as transition zones.
3. The map is intended to provide a regional overview and should not be used to draw conclusions about conditions at specific locations.
4. Under no circumstances must the scale of the map be enlarged beyond its scale of mapping.
5. Advice from DMLBC Soil and Land Program should be sought prior to using this information for commercial decision making.
6. Under no circumstances may the data or information associated with this map or any accompanying report be altered in any way without the express permission of DMLBC Soil and Land Program.

DISCLAIMER: The Department of Water, Land and Biodiversity Conservation (DMLBC), its employees and servants do not warrant or make any representation regarding the use, or results of use of the information contained herein as to its correctness, accuracy, currency or otherwise. DMLBC, its employees and servants expressly disclaim all liability or responsibility to any person using the information or advice contained herein.

LAND ASSESSMENT: Soil and Land Program, DMLBC.
MAP PRODUCTION: Resource Information, DMLBC.

MAP PROJECTION: MGA Zone 54 **MAP DATUM:** GDA94

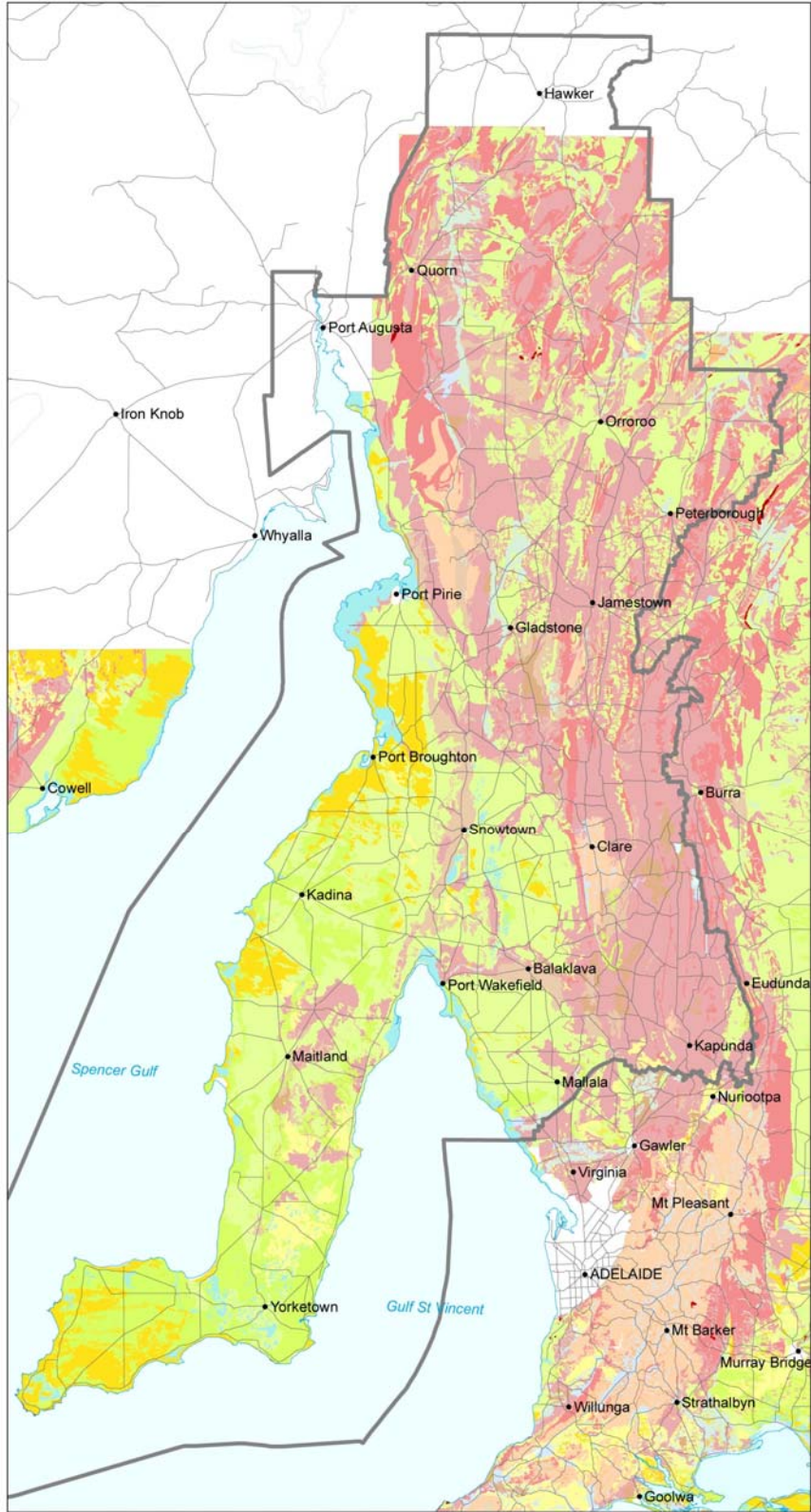

Government of South Australia
Department of Water, Land and
Biodiversity Conservation

© Government of South Australia, through the
Department of Water, Land and Biodiversity Conservation 2006
This work is copyright. Apart from any use as permitted under the Copyright Act
1969 (Cwth), no part may be reproduced by any process without prior written
permission from the Department of Water, Land and Biodiversity Conservation.
Requests and inquiries concerning reproduction and rights should be addressed
to the Chief Executive, Department of Water, Land and Biodiversity Conservation,
GPO Box 2834, Adelaide SA 5001.

Natural Heritage Trust
Helping Communities Help the Environment
An Australian Government Initiative

p4333mcs:NYR_SoilsGroup.mxd 29/06/2006 JMR

Rainfall and Evaporation

Guideline No 6.



To determine your winter dairy effluent storage requirements you will require rainfall and evaporation data for your property location.

To determine your effluent storage capacity you will need to calculate a number of factors including the amount of rainfall runoff from dairy yards, roof surface area that drains to the effluent system, dairy wash water, and rainfall on the ponds themselves.

Determining Winter Storage Requirements

Over most of the region monthly effective¹ rainfall is less than the average evaporation. The table below shows the months in which the effective rainfall exceeds evaporation for different rainfall recording stations.

LOCALITY	MONTHS EFFECTIVE RAINFALL EXCEEDS EVAPORATION	May	Jun	Jul	Aug
Auburn	0				
Balaklava	0				
Blyth	0				
Booborowie	0				
Clare	2				
Farrell Flat	0				
Hoyleton	0				
Kapunda	0				
Laura	0				
Mallala	0				
Marrabel	0				
Riverton	0				
Tarlee	0				

The table shows the months for which wet weather storage of dairy shed effluent is likely to be required in the Northern and Yorke region. The table shows that winter storage is only likely to be required in the higher rainfall districts such as Clare. Actual storage time may need to be extended for two weeks before and two weeks after the months shown to allow soil moisture conditions to become suitable for irrigation. For Clare the actual storage required could extend from mid-May to mid-August – a period of three months, or 90 days.

Developing an irrigation schedule based on crop water use and soil moisture deficit principles will give better accuracy to the calculation of minimum storage time.

Calculating Effluent Storage Capacity

Once the storage period is defined (refer to graph, usually in months) the minimum storage volume can be calculated. The storage capacity will be the sum of the:

- 1) dairy effluent wash-water;

¹ Effective rainfall can be estimated from average rainfall. Average rainfall in months with less than 75 mm multiply by 0.6, months over 75 mm multiply by 0.8.

- 2) rainfall and runoff which lands on the dairy yards and roof that drains to the effluent system
- 3) rainfall on the storage pond itself.

In order to calculate the volume of water that is captured by the yards, roof and storage pond local rainfall data needs to be assessed. The 90 percentile rainfall figures of the contributing storage months is then multiplied by the area of the dairy catchment, (rainfall and runoff which lands on the dairy yards and roof that drains to the effluent system). The 90th percentile rainfall is approximately 1.5 times the average rainfall for the specific period.

Other areas feeding effluent into the ponds must also be accounted for, such as laneways, adjacent yards, and feeding sheds or feed pads. Again, the 90 percentile rainfall should be used.

Spreading Effluent During Times of High Rainfall

Spreading of effluent during the period when rainfall exceeds evaporation may be possible depending on the ability of pastures or crops to utilise the nutrients applied. An Irrigation Management Plan (IMP) should be developed to determine the feasibility of spreading effluent during this period. For more details refer to ***Guideline 12 : Irrigation Management Plans.***

Temperature and Pasture Growth

Guideline No 7.

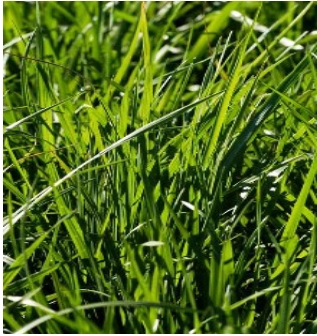

Low temperatures slow the mineralisation of nitrogen in dairy shed effluent. Low temperatures also slow the rate of pasture growth.

A dairy effluent storage system should be considered during times of low temperature and low pasture growth to minimise the risk of nutrients entering groundwater and surface water systems.

Effects of Temperature on Pasture Growth

Temperature has a significant effect on pasture growth. High and low temperatures can inhibit the growth of pastures and crops. High temperatures are possible each summer in the Northern and Yorke region, normally at the time when dryland pasture growth has stopped. Unless pastures are growing under irrigation the high temperatures have little effect on nutrient uptake and pasture growth. The region, however, does experience low temperatures during winter, which may reduce the growth of pastures. Low temperatures slow down the mineralisation of the nitrogen in dairy shed effluent and restrict the uptake of nutrients by plants. This means that the nutrients in effluent applied during this period will not be taken up by plants and therefore increase the risk of them entering surface or groundwater systems.

Months when average minimum temperatures are less than 6°C and average maximum temperatures are less than 15°C are likely to have soil temperatures of less than 10°C, which will cause mineralisation of nitrogen and pasture growth to both slow down dramatically.

There are limited temperature records for region. The tables show the months during which average daily temperatures could be expected to limit mineralisation and pasture growth for the two sites for which records are available.

LOCALITY	MONTHS AVERAGE MINIMUM TEMPERATURE IS LESS THAN 6 Deg C	Apr	May	Jun	Jul	Aug	Sep	Oct
Clare	5							
Kapunda	2							

LOCALITY	MONTHS AVERAGE MAXIMUM TEMPERATURE IS LESS THAN 15 Deg C	Apr	May	Jun	Jul	Aug	Sep	Oct
Clare	0							
Kapunda	0							

The tables show the months during which pasture growth is likely to be inhibited by low temperatures. There are no months on record where average maximum temperatures are less than 15°C. Pasture growth, however, is likely to be inhibited by low average minimum temperatures.

Low pasture growth means that the uptake of nutrients by the pasture is also low.

During the months in which pasture uptake of nutrients is low, the spreading of dairy shed effluent is not advisable. Storage is recommended over this period until pasture growth and the uptake of nutrients by the pasture increases.

Advantages of Storing Effluent Over Slow Pasture Growing Periods

There are distinct advantages in storing the effluent over the period when pasture growth is low. Superior utilisation of the nutrients it contains will be achieved when spread during the spring and summer months. This will help offset some of the cost of installing an effluent storage. Another significant advantage is the saving in the additional infrastructure, which would be required to spread the effluent over a larger area. For example, based on pasture growth rates, if the effluent is not stored, the area required for spreading the effluent could be from 4–8 times the area required for spreading in spring and summer. This would require a much larger investment in the distribution system.

Solids Separation Systems

Guideline No 8.



Separation of solids from your dairy effluent increases the flexibility of the effluent management system.

The removal of solids from dairy effluent can be achieved through the use of gravity or mechanical systems.

This guideline reviews the following systems which remove solids from dairy effluent: Trafficable Solids Trap, Sedimentation Systems, Screen Separation, Presses, Centrifugation and Hydrocyclones.

Solids

Removal of solids increases the flexibility of effluent treatment systems. Separation of the larger solids reduces blockages, decreases sludge build-up in ponds and separates slowly degraded material from more quickly degraded material.

Removal of the larger solids also lowers the organic matter and nutrient content of effluent. The solids are easily handled and can be stacked, composted, spread on land or moved off-farm if necessary. The moisture content of the separated solids varies according to the system used and its operating conditions.

The Solids Separation Process

The effectiveness of separation depends on the type of separation device and the effluent characteristics. Generally speaking, as the concentration of solids in the effluent increases the percentage of solids which are removed increases.

The separation of solids from the liquid portion is usually achieved by using the effects of gravity or by using a mechanical device. Mechanical separation typically may involve a screen, press or centrifuge.

Drawbacks of mechanical separation include:

- a) High cost - Along with the expense of the separating device, some mechanical separating systems have high energy operating costs. Also, two separate manure handling systems are needed, one to handle the liquid fraction and the other for the solids stream.
- b) Increased management requirements - An operator must ensure the system is functioning properly. Regular maintenance may be required to avoid breakdowns, depending on the type of separator.

Trafficable Solids Trap

The details of design and construction of trafficable solids trap can be found in the Victorian Agricultural Note fact sheet “Dairy Effluent: Trafficable solids trap” a link to which is included with these guidelines.

The proportion of solids removed by the solids trap will largely depend on the spacing of the timbers in the baffle. Spacings between 15 and 25 millimetres are recommended.

Trafficable solids traps can be designed to handle hose wash and flood wash yard cleaning systems.

Trafficable solids traps are not suited to large herds

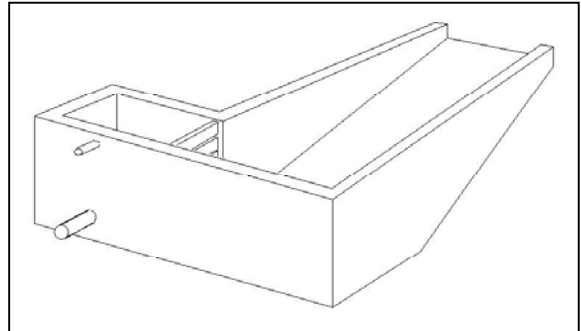

Diagram of a Trafficable Solids Trap

Sedimentation Systems

Sedimentation systems rely on gravity to settle the heavier particles. Settling has the potential to remove more solids than most alternatives but requires more management. In closed ponds and solids ponds/trenches the settled material can be handled as a slurry and removed with a waste tanker or the effluent can be drained into a storage lagoon or holding tank. The solids then can be removed with a front end loader. Alternatively a number of evaporation terraces can be used which will allow the sludge to dry even further and be removed with a loader and truck.

Sedimentation systems are usually a basin or terrace system. For basins and terraces, settling occurs when the flow of the effluent is slowed as the effluent moves across the structure. The denser particles then settle to the bottom by gravity.

Normally 50% of solids will settle within one minute and 75% within 10 minutes. The remaining solids can only be settled by the addition of coagulants such as lime.

Settling basins should be shallow, typically 0.6–1.0 metres deep, long, wide and free draining with the effluent moving on to a storage lagoon or holding tank. The design flow rate through the basin should be less than 0.3 m/sec with a hydraulic retention time of at least 20–30 minutes. A front-end loader can be used to remove the solids every 1–2 months. Regular removal is necessary to prevent the development of septic conditions or sludge re-suspension.

Gravity systems can be used with large herds but they need to be sized accordingly. The system needs to be able to manage large amounts of water and solids. Generally, because of the size of the structure, odour may become an issue.



Settling basin with drop board weir

Screen Separation

Screen separators include stationary inclined, vibrating, rotating and in-channel flighted conveyor screens. All separators of this type involve a screen of a specified pore size that allows only solid particles smaller in size than the openings to pass through. This type of separator generally works best with effluent having a solids content of less than 5 %.

1- Stationary Screen

Liquid manure is pumped to the top edge of the inclined screen. Liquids pass through the screen while the solids accumulate on the screen and eventually move downward due to gravity and fluid pressure.

This system has no moving parts or power requirements with the exception of a pump needed to move the liquid manure to the top of the screen. The drawback of the stationary inclined screen separator is that a biological slime builds up and clogs the openings. Frequent brushing is necessary to ensure the holes remain open.

The “Wedge-Wire” screen with automatic washing reduces the tendency for this type of solids separation system to block up.

The stationary inclined screen is capable of removing **60% of the total solids** from dairy shed effluent.

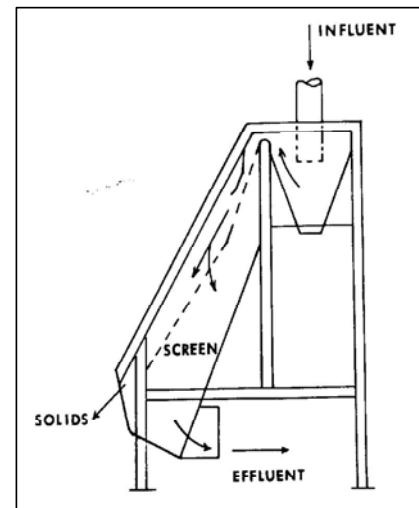

Diagram of a Stationary Screen



A “Wedge-Wire” screen in operation

2- Vibrating Screen

Liquid manure is pumped onto the flat vibrating screen at a controlled rate. The liquid flushes through the screen while the short, rapid reciprocating motion employed moves the solids to the screen edge where they are collected. The vibration reduces clogging of the screen. The power requirement is higher with this system than with the stationary inclined screen.

The vibrating screen can remove between **5 and 20% of total solids** from dairy effluent, depending on screen aperture size and solids content of the effluent.

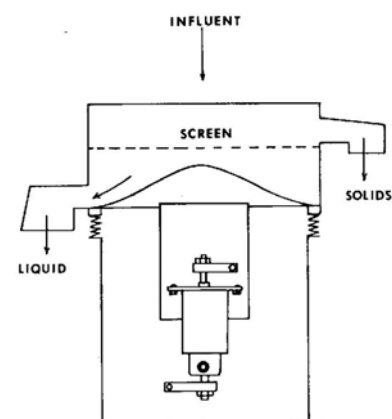

Diagram of a Vibrating Screen

3 - Rotating Screen

A continuously turning or rotating screen receives liquid manure at a controlled rate. The liquid passing through the screen is collected in a tank while the retained solids are scraped from the surface into a collection area.

The rotating screen can remove up to **14% of total solids** from dairy effluent at low flow rates but as the flow rate increases the percentage of solids removed declines.

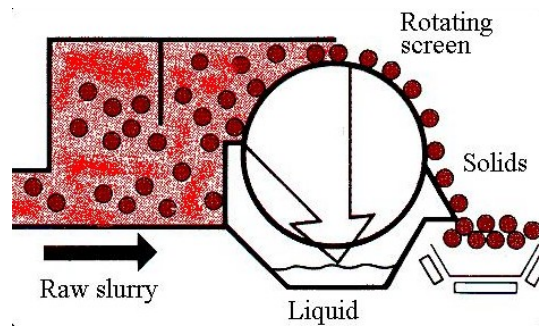

Diagram depicting the function of a rotating screen

4 - In-channel Flighted Conveyor Screen

This screen separator system consists of an inclined screen and a series of horizontal bars called flighted conveyors. The separator can be placed directly in an open manure channel, which eliminates the need for a sump or a pit and a lift pump. Liquid passes through the screen and drains into the channel on the downstream side of the separator, while the separated solids are deposited on a collection pad.

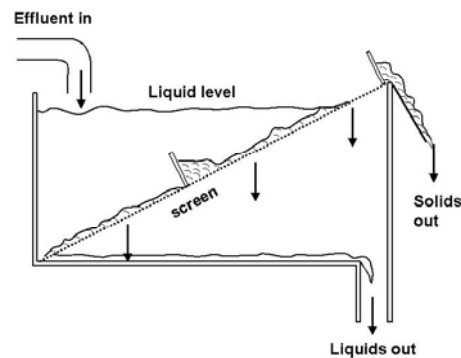

Diagram of an In-channel Flighted Conveyor Screen

Uses are similar to those of the stationary inclined screen separators, but the in-channel flighted conveyor screen separator requires more mechanical maintenance because its moving parts are exposed to corrosive and abrasive materials.

The in-channel flighted conveyor screen can remove up to **5% of total solids** from dairy effluent.

5 – Baleen Filter

This screen separator consists of a woven stainless steel screen manufactured to micron specifications.

The Baleen filter can handle up to 10 litres per second at approx. 50 micron per square metre of filter screen media, and may remove in excess of 75% of suspended, settle-able solids in waste streams with 10,000 ppm of suspended solids.

The screen is regularly flushed clean by water jets to prevent blockages.

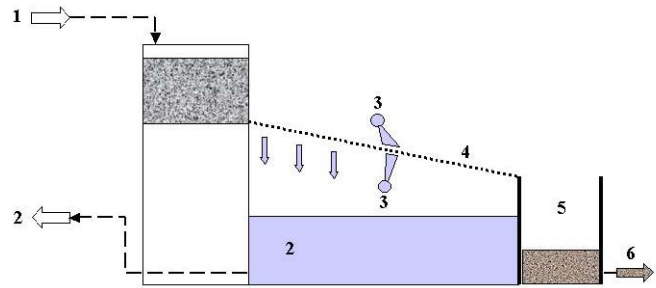

1. effluent inflow
2. filtrate
3. moving spray system
4. micro screen
5. solids bin
6. residual water

Presses

Presses act as continuously fed de-watering devices that involve the application of mechanical pressure to provide additional separation of the manure slurry. They are often used to remove additional water from the separated solids portion produced following screening or centrifugation. This physical separation process typically achieves a high level of de-watering and the pressed solid cake can be composted or spread on land. The three main types of mechanical filtration devices are roller, belt and screw presses.

1 - Roller Press

This type of press has two concave screens and a series of brushes or rollers. The manure slurry is initially deposited onto the first screen and then moved across the two screens with brushes and squeezed by the rollers. The liquids are squeezed through and the solids remain on the screen. The following two separators use these principles in their operation.

- a) The **Brushed Screen with Press-Rolls**, also referred to as a Brushed Screen/Roller Press, separates manure using a screen in the first stage of the process. The screen is kept clean by a rotating brush which moves the solids on to the next stage. Here, a roller presses more liquid out of the solids. The concentrated solids are then brushed out of the separator and transferred to storage.

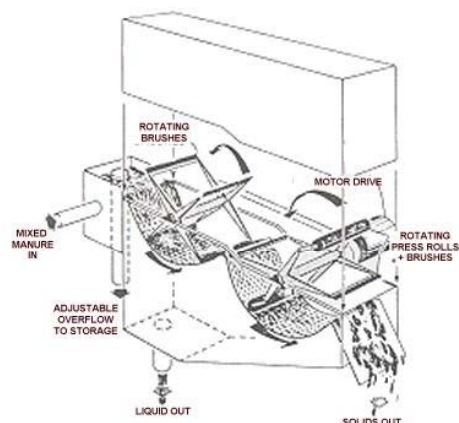

Diagram displaying the function of a Brush Screen with Press-Rolls

Brushed screen roller presses can remove up to **18% of total solids** from dairy shed effluent at a flow rate of around 100 litres per minute. The flow rate is governed mainly by the nature of the fibre in the manure in the effluent. As flow rate increases the percentage of solids removed decreases.

- b) The **Perforated Pressure Roller Separator** is a two-stage double roller compression separator. Liquid slurry is force-fed into the first set of perforated separator rollers. Separated liquid is removed at this point for storage. Separated solids from the first stage are conveyed to the second set of separator rollers where the fibre solids are removed by a mechanical conveyor to the storage area. The liquid fraction is drained off at this point and returned to the initial liquid slurry tank.

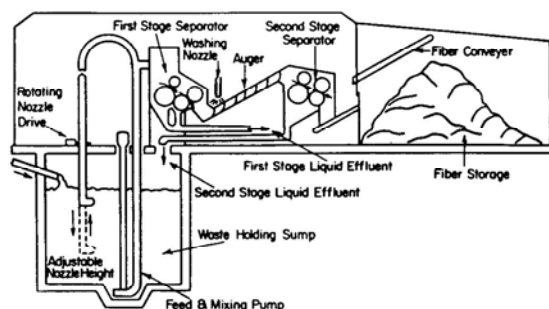

Diagram of a Perforated Pressure Roller Separator

Perforated pressure rollers can remove up to **25% of the total solids** from dairy effluent which has a total solids content of

about 10% at a flow rate of 250 l/min. As the solids content of effluent declines the rate of treatment increases but the percentage removed declines. Effluent with a total solids percentage of 4.5% can be treated at 360 l/min but only 10% of the solids are removed.

2 - Belt Press Separator

The belt press consists of a flat, woven, fabric belt that runs horizontally between rollers. The liquid is forced through the belt by the rollers and the solids are carried along on the belt and dropped into a solids collection chamber.

The belt press separator is capable of removing around **33% of total solids** from dairy effluent.

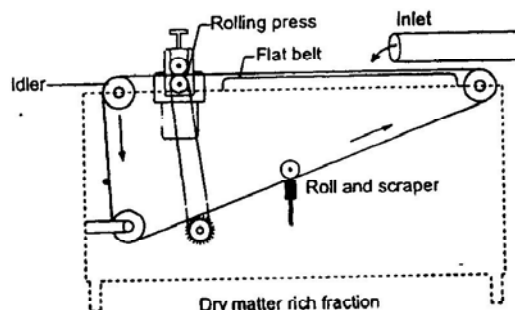

Diagram of a Belt Press Separator

3 - Screw Press Screen Separator

The screw press is composed of a screw-type conveyor in the centre that forces the slurry through a tube and past a cylindrical screen. The screw conveys the solids retained on the screen to the end where the solids are then discharged.

Screw presses are capable of removing **25 – 45% of total solids** from dairy effluent at an average flow rate of 115 l/min. The low rotational speed of the screw press requires very little power to operate.

The press can be operated to meet the particular needs of the operator.

- a) **To maximise flow rate:** - operate the press under pressure with low influent solids.
- b) **To maximise the fibre output rate** (e.g. in kg/min) - operate the unit with as high an influent DM concentration as possible with lower outlet resistance.
- c) **To achieve the driest solids** - operate the unit with the most outlet resistance and a high influent solids content.
- d) **To remove as many nutrients as possible** - keep the influent solids as high as possible with minimal dilution.

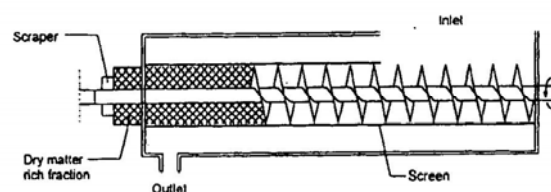

Diagram of a Screw Press Screen Separator



A FAN Screw Press separator

Centrifugation

Centrifugation involves solid-liquid separation using centrifugal forces to increase the settling velocity of suspended particles using either centrifuges or hydrocyclones. These separators function best with liquid slurries of 5-8% solids and are not as efficient when the solids content is lower.

Typically centrifuges consist of a horizontal or vertical cylinder which is continuously turned at high velocities. Centrifugal forces separate the liquid and solids onto the inside wall of the cylinder into two layers. An auger, which turns slightly faster than the cylinder, moves the solids to the conic part of the unit where they are discharged.

The two types of centrifuge separators are centrisieves and decanters.

Centrisieves (top image) consist of an inclined revolving drum that is lined with a filter cloth. The slurry to be separated is pumped into the drum centre. The liquid leaves the drum through the filter cloth and the solids move by centrifugal force to the edge of the drum where they are removed separately.

In the case of **decanter centrifuges** (right image) an auger, turning at a slightly higher speed than the cylinder in which it is contained, moves the slurry to the conic part where it is discharged. Centrifuges are very effective at solids separation and can achieve relatively low moisture levels. The initial cost is high and the energy requirement is also quite high in comparison to other systems

Centrifuges are capable of removing **45 – 65% of total solids** from effluent. Despite their relatively high power requirement they are suitable only for relatively low flow rates (10 – 30 l/min) and as the flow rate of effluent increases their efficiency declines.

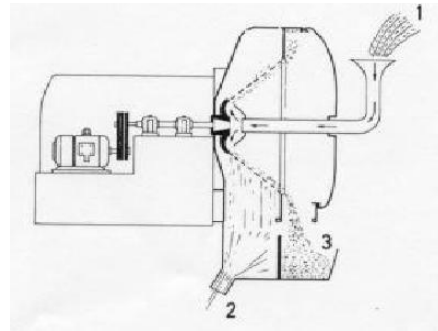

Diagram of a Centrisieves Centrifuge Separator

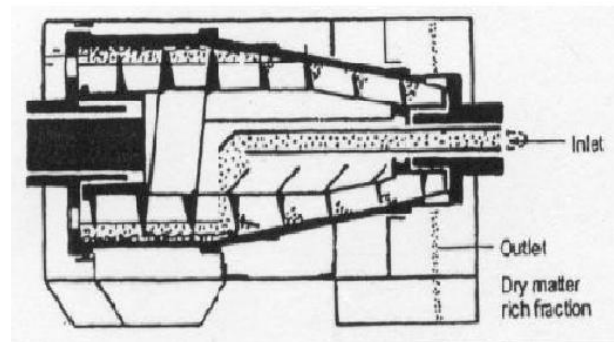

Diagram of a decanter centrifuge

Hydrocyclone

Hydrocyclones are cone-shaped separators that have no moving parts and the necessary vortex motion is performed by the liquid itself.

They are configured so that when manure is pumped at an angle into the cylinder (near the top), it swirls at a high speed. The strong swirling motion accelerates the gravity settling of solid particles to the bottom of the cone while the liquid is discharged through a cylindrical tube fixed in the centre of the top.

The hydrocyclone is capable of removing about **8 % of the Dry Matter** in effluent at flow rates of about 250 L/min. This level of performance is unlikely to be suitable for the separation of dairy shed effluent.

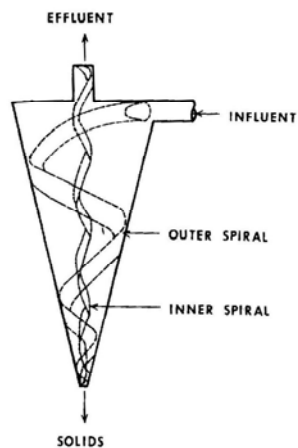

An example of a Hydrocyclone Separator

Important Notice:- The information provided in this fact sheet is sourced from product information and research evaluations. Although all reasonable care has been taken in the preparation of the information contained in this document, it has only been provided in good faith for general information only. No warranty, express or implied, is given as to the completeness, correctness, accuracy, reliability or currency of that information. The information in this document is not intended to be exhaustive or to replace the need for persons interested in such information to make their own enquiries or to seek independent advice.

Environmental Guidelines for Effluent Ponds

Guideline No 9.



There are four environmental considerations that are important in the design and management of dairy effluent ponds. These are:

- Pond Structure and Location
- Pond Maintenance
- Odours and Pond Health
- Contingency Plans

This is not a guideline on how to construct effluent ponds. Its purpose is to highlight some of the environmental considerations which are important in the design and management of dairy effluent ponds.

All ponds must be designed to prevent any unapproved/non-permitted or uncontrolled discharge of untreated effluent, partially treated effluent or reclaimed water to adjoining land, soils, groundwater, water bodies or marine environment.

1) Effluent Pond Structure and Location

Storage Pond Base:

The base of the storage pond must be more than one metre above the highest seasonal groundwater level.

Embankments:

Provide embankments to prevent inflow of stormwater/ surface runoff or outflow of effluent, similarly provide extra storage to prevent overtopping.

Minimum embankment freeboard should be 600 millimetres above design storage capacity.

In areas with potential for inundation, the embankment of the pond must be above the one in 25 year flood level or maximum high tide level for that area, whichever is the highest.

Pond Lining:

Effluent Ponds should be lined with an impervious material, eg compacted clay and/or synthetic membrane to prevent seepage.

Clay Lining:

- a) All clay linings should have a minimum compacted thickness of 600 millimetres;
- b) Any clay used for lining of an effluent pond must have a permeability of no greater than 1×10^{-9} m/sec. Testing of the material by a Geotechnical Engineer will ascertain the permeability of the material and its optimum moisture for compaction.
- c) Clay Lining should be protected from desiccation during construction of the pond;

Synthetic Membranes:

- a) Membranes should have a smooth finish on both sides and not embossed;
- b) Membranes should be uniform in thickness across the entire area of the lining;
- c) All membranes should be free from pinholes, blisters and contaminants;
- d) All joints and seals on membranes should be tight to ensure membranes are water tight;

Location:

Ponds used for storage or treatment of dairy shed effluent must not be located

- Closer than 100 metres to a residence built on land that is owned by some other person;
- Closer than 20 metres to a public road;
- Where it is likely to be inundated or damaged by water during a flood which has an average recurrence interval of one in 10 years or greater;
- Within the 1956 River Murray Flood Plain.

2) Pond Maintenance**General Maintenance:**

Banks must be checked for evidence or indications that erosion has or will take place

All fences must be in satisfactory condition.

Structures:

- a) All inlet and outlet pipework and structures must be checked regularly to ensure they are operating effectively.
- b) All pumps must be checked to ensure they are working.

Weed Growth:

- a) Banks of the ponds should be checked for any weeds that are on the water surface or at the water line. Weed growth in these areas can encourage mosquito breeding. Weed control can be done by a suitable herbicide or regular maintenance.
- b) The upper banks should be planted with pasture or other vegetation to prevent erosion or collapse of pond edges due to wave action. Trees are not suitable for growing on the banks of ponds.

Cleaning Ponds:

Ponds should be designed to ensure efficient cleaning and desludging:

i) Weeds:

There is no precise schedule for when to remove weeds from ponds. Some weeds may even be helpful in reducing the nutrient concentration in the final effluent.

Some indications that weed control may be necessary:

- a) When the weeds form a mat over the pond and the surface is no longer visible.
- b) When there is evidence that retention times in the ponds are shorter than required due to weed build up reducing the capacity of ponds.

ii) Desludging:

- a) Sludge levels should never exceed more than 60–70% of pond capacity.
- b) The clay lining of ponds must be checked after desludging to ensure it's structure and integrity has not been damaged or compromised. Any damage to lining will need to be repaired before water can be reintroduced into that pond.

3) Odours and Pond Health

A properly functioning effluent treatment system will have negligible odour. When performing correctly it will also have a typical colour and appearance.

All ponds do have some odour due to the nature of the treatment processes that occur. All systems will exhibit some odours during periods of little wind movement.

Objectionable odours and the change of the appearance and health of the ponds can result from many things:

- a) Algal growths and decomposition of algal matter.
- b) Low light and intensity coupled with reduced algal growth can cause septic conditions in the ponds.
- c) High temperatures stimulating anaerobic bacteria at pond floor and resultant increased loadings and possibly anaerobic conditions prevailing.
- d) Overloading of ponds.

It will be important to establish the reasons and source of the poor health of the ponds. The remedy should address the cause not just the symptoms.

4) Contingency Plans

It is recommended that a Contingency Plan be put in place, which outlines procedures to be taken during incidents such as:

- 1) blockages on inlets and principal drainage lines.
- 2) failure of mechanical or electrical equipment – pumps, aerators.
- 3) flooding, ingress of stormwater, and egress of effluent.
- 4) odour problems.

Effluent Pond Construction

Guideline No 10.



To satisfy the mandatory provisions of the Environment Protection (Water Quality) Policy 2003, all ponds must be lined with a suitable liner to prevent leaching of waste.

This guideline will discuss the use of natural clay and synthetic membrane as liners for dairy effluent ponds.

Effluent Pond Construction

Effluent ponds should be lined on the bottom and sides with compacted clay and/or a synthetic membrane sufficiently impermeable to prevent any waste from leaching through the lining.

All effluent ponds must comply with the mandatory provisions of the Environment Protection (Water Quality) Policy 2003. Operators of effluent ponds must be able to show evidence that the pond liner meets the leaching rate for effluent pond liners of less than $1 \times 10^{-9} \text{ ms}^{-1}$. Testing of the clay can be conducted by a Geotechnical Laboratory. Specifications of other liners can be obtained from the manufacturer or installer.

1) Natural Clay Lining

A clay lining should be protected from desiccation during construction of the pond. Also, if groundwater is encountered during excavation then the site must be de-watered and dried, to an appropriate dryness as determined by a certified engineer, before being lined with clay.

Where the natural geology of the site is proposed for use as the barrier system, an extensive hydrological investigation should be conducted by a certified engineer to prove the efficiency of the barrier.

This assessment should include but not be limited to:

- The extent of the material.
- The permeability of the material to water at varying water contents and bulk densities.
- The integrity of the material and the presence of any imperfections that may compromise its effectiveness (such as root holes, cracks, or gravel layers).
- Any possible reactions between the material and the liquids treated.

Clay lining alone is not suitable for an evaporative pond, as the lining will lose its effectiveness as it becomes exposed to the air and dries out. To prevent the clay lining from drying out a covering layer of crushed rock or sand can be used as a “mulch”.

The material used to line clay ponds should be well graded, highly impervious and conform to the particle size distribution and plasticity limits listed below.

Particle size distribution	
AS metric sieve size (mm)	Percentage passing (dry weight)
75.000	100
19.000	70-100
2.360	40-100
0.075	25-90

Plasticity limits on fines fraction, passing 0.425 mm sieve

Liquid Limit W_L	30-60%
Plasticity index I_p	>10%

If materials complying with the above plasticity limits are not readily available, clays having limits between 60% and 80% may be used as lining material, provided that the clay lining layer is covered with a layer of compacted gravel (or other approved material). The compacted gravel layer should prevent the clay lining from drying out and cracking.

Topsoil, tree roots and organic matter must not be used as lining material.

The following issues also need to be considered when constructing a dairy effluent pond using a natural clay lining.

Permeability

The re-compacted clay or modified soil liner must have an in-situ permeability of less than $1 \times 10^{-9} \text{ ms}^{-1}$. A geotechnical consultant should be consulted to determine the correct lining thickness and the finished lining must be tested to ensure that it meets the permeability criteria. This permeability must be maintained throughout the lifetime of the pond. On going maintenance to keep the pond banks free of vegetation can assist in this. Trees shall not be allowed to grow in either the base or banks of the pond.

Volume

The capacity of the pond should be such that, on top of the treatment volume of effluent, it can accept rainfall from one-in-25-year, one-day duration storm event without overflowing. There must also be sufficient freeboard above this capacity so that waves generated by the wind do not flow over the tops of walls.

Layers

Successive layers should be of compatible materials and of similar water content and each underlying layer should be scoured to prevent excessive permeability due to laminations. The thickness of each layer, the compaction and the control of water content are all to be carefully controlled so as to optimise the clay compaction for maximum impermeability.

Embankments

The sides should generally have a slope not exceeding a gradient of one vertical to three horizontal (battering of wall relates to material), in order to allow suitable compaction of the barrier and to facilitate subsequent testing. The embankments must be constructed to prevent leakage beneath the wall. The mechanical strength of the wall must be such that it prevents erosion from rainfall and runoff. The internal faces must be protected from wave erosion.

Cover Protection

Compacted clay linings must be covered immediately and kept moist to prevent volume instability and desiccation. Desiccated sections should be removed, broken up, re-wetted and re-compacted. The placing and compaction procedures shall be carried out in such a way as to prevent the drying out of the clay. The clay liner shall be permanently protected from mechanical damage and drying-out with a compacted layer of sand or gravel (minimum thickness 100 millimetres).

Possible Reactions

Any possible reactions between the material and liquids treated should be considered. These reactions may be affected by pH (acidity / alkalinity). Compacted clay linings should be compatible with the leachate to be retained (that is, hydraulic conductivity should not increase over time when exposed to the leachate).

Access for Desludging

The pond should be designed to allow truck access for desludging. To assist de-watering and desludging the pond floor should have a gentle slope towards the access point.

2) Synthetic liners

Synthetic liners include PVC (polyvinyl chloride), HDPE (high-density polyethylene), GCL (Geosynthetic Clay Liner) or concrete. The issues of permeability, volume, embankments and possible reactions listed under natural clay linings must also be considered for synthetic liners.

Other considerations for a suitable synthetic liner include the following:

- Allow for the supply and placement of one layer of synthetic liner over the floor and all sloping sides of the pond.
- Membranes should have a smooth finish on both sides and not be embossed.
- Membranes should be uniform in thickness across the entire area of the lining.
- Membranes should be free from pinholes, blisters and contaminants.
- All welded joints and seals on membranes should be tight to ensure membranes are still watertight.
- To extend their life, membranes can be covered with a minimum of 500 millimetres of suitable material. This cover must not contain sharp or jagged rocks, roots, debris or any other material that may be abrasive or may puncture the membrane (for example, sand may still contain sharp material). The cover material must be applied in a manner that does not damage the lining and must allow access of machines to desludge the

pond without damage to the membrane. Covering the membrane is common in industrial applications, but is not often used in dairy effluent systems.

- Certification should be provided stating that the membrane used for the pond has met all necessary requirements.
- Membranes should be laid cautiously and in accordance with the manufacturer's directions.
- Ponds lined with synthetic liners, particularly HDPE usually need to be de-sludged using a vacuum tanker. To prevent damage to the liner, concrete pads should be located on the bottom of the pond and clearly marked so that the agitation equipment and the tanker suction line can be accurately placed in them and avoid chafing or puncturing the lining.

Maintenance

The lining of the effluent pond will deteriorate over time. HDPE liners are chemically inert but will degrade over time due to the effects of sunlight. Indicative life spans for sections of liner exposed to sunlight are about 25 years for 1.5 millimetre HDPE liner and up to 35 years for 2.0 millimetre liner. Clay liners should have a lifespan of more than 30 years but this will depend on the thickness of the clay blanket which has been installed.

Monitoring bores will be required to allow monitoring of the groundwater to ensure that groundwater contamination is not occurring (*Refer to Northern and Yorke No.19 – Monitoring the Effluent Management System*).

Shape and Size of Ponds

When deciding on the size and shape of ponds consideration must be given to how the pond will be emptied and de-sludged.

Consider the reach of excavators which may be used to remove surface crusts or settled sludge. Access from a number of locations around the pond may be required. Long narrow ponds are best suited to clean-out with excavators, but are difficult to stir with mechanical agitators for emptying with suction tankers. Mechanical stirrers work best in ponds which are square.

Ponds which are too large are difficult to clean out. Consider installing two or three smaller ponds of a size which can be easily cleaned out.

Ponds lined with HDPE liners should have take-off points installed in the base with pipes laid underneath the liner to quick coupling fittings on the bank. This will allow suction tankers to be filled without inserting their normal loose piping into the surface of the pond which may damage the liner. HDPE lined ponds can be mixed with an agitator mounted on an excavator arm, which avoids inserting tractor or electric powered agitators from the bank of the pond and the high risk of damage to the liner.

Equipment

Guideline No 11.



When considering a dairy effluent management system you need to evaluate the system as a whole. This means not only deciding on the best kind of system that suits your dairy but also the type of supporting equipment that might be required.

This includes sumps and storage tanks, pumps, pipes and sprinklers.

Sumps and Storage Tanks

Sumps are in ground collection points for dairy effluent prior to storage or applying it to pasture. They can be designed for either minimum storage or buffer storage. When deciding to install a collection sump, you need to be clear about which type of sump you will be installing.

In minimum storage sumps, the effluent has to be pumped out almost as quickly as it flows in. The effluent does not have time to settle and therefore agitation is not usually necessary in these sumps. However, a stone trap is **essential** to minimise problems with the pump. The sump acts as a collection point only and problems can occur if the pump fails.

Backup systems for minimum storage sumps should be incorporated into the design plan. These may include an electricity generator for power failures, a back-up pump for breakdowns of the primary pump or a short term (minimum two days) holding tank.

(Refer to Guideline No. 18 : Emergency Backup Plans).

Buffer storage sumps give more capacity to cope with pump failure since the sump should be designed to store the effluent from two or more days without overflowing. A buffer storage sump should be emptied after each milking to reduce the need for agitation to keep solids in suspension. A stone trap will help to minimise problems with the pump.

Trafficable sumps are used to settle out solids, making the remaining liquid easier to pump. Sumps that hold effluent for any length of time need to be at least 20 metres from the milk room.

Storage tanks are designed to store the effluent for one week or more. They can be used in combination with slurry tankers or pumped direct to pasture.

Tanks which are pumped usually require mixing to keep manure solids in suspension. Ensure that the mixer and the pump can be removed easily for cleaning or maintenance.

Sumps or storage tanks which are used to spread direct to pasture may also require wet weather storage for the period of the year when rainfall exceeds evaporation and effluent can not be spread on paddocks safely.

Pumps

Pumps are critical in most effluent management systems, yet they probably cause more problems than any other part of the system. As a general rule, the more effective the solids separation system, the fewer problems which will occur with the pumps.

Use a pump that is designed to handle dairy effluent. If the effluent contains solids it is important to select a pump that has the capacity to pump rapidly enough to prevent solids settling out in pipe-work.

Reliability is essential as the consequences of having a pump out of action for any length of time can be serious. All pumps will break down occasionally and need maintenance. Mount the pump in a position where it is easy to access. It is strongly recommended that you use a purpose-built manure pump, regardless of whether or not a solids separation system is used.

Agitation of the effluent to be pumped keeps the solids in suspension and can help the performance of the pump. A bypass line or a freshwater hose inlet are simple methods to keep the collection vessel agitated. Mechanical stirrers can also be used.

Characteristics of some common types of effluent pumps are shown in the table below.

Characteristics of some common types of pumps

Type of pump	Maximum solids content	Pump head (m)	Power needs range (kW)	Applications	Comments
Conventional centrifugal (horizontal shaft)	5%	>60	2.2 - 35	recirculation	must have high quality effluent
Open and semi-open vertical shaft	15%	<25	2.2 - 40	transfer to storage, gravity irrigation, tanker filling	low lift capability avoids priming and foot valves
Submersible centrifugal	15%	<10	2.2 - 7.5	transfer to storage	low lift capability, uncommon
Diaphragm	20%	<10	0.75 - 7.6	transfer to storage	very simple in operation
Helical screw (rotor)	6%	>60	2.2 - 30	sprinkler irrigation, pumping over long distance, pumping to elevated storage	good for high solids; abrasive material can destroy stator
Piston pump	20%	<10	7.5	transfer to storage of fibrous material, sludge pumping	limited use for effluent, good for solids and slurries
Vacuum pump	10%	max lift 3.5 m	3.75 - 40	tanker loading, priming siphons	good for livestock effluent

Pipes

The type of pipe required will depend on what the pipe is expected to carry. If the pipe is expected to move effluent containing solids by gravity, at least 150 millimetre pipe will be needed. Blockages will be a problem with anything less than this. Separating out the solids makes it easier to move the remaining liquid.

Talk to your supplier about what you will need for your particular circumstances. Distance pumped, head and presence or absence of solids all need to be considered when designing the system. You also need to consider what effect sunlight might have on the performance of the pipe. If the pipe is designed to be buried, leaving it on the surface may reduce its performance and will shorten its life.

When choosing and laying out the pipe-work consider the following:-

- If the fall is from one in 60 to about one in 80, use 200 millimetre pipe if relying on gravity. If the fall is less than this, use a pump.
- Use sewer class pipe rather than storm water.
- If pumping more than about 100 metres or more than about 10 metres static head, use 75 millimetre, class 4.5 pipe. 50 millimetre pipe can be used for shorter distances or lower heads.
- UPVC pipe can normally handle higher pressures than polythene pipe but has less flexibility to handle surge pressure.
- Leaving PVC pipe uncovered on the surface for only a few months can halve the life of the pipe compared to being installed underground.

Sprinklers

Regardless of whether raw effluent or effluent from which the solids have been removed is being spread, use a sprinkler which has been designed to handle effluent.

Whether the sprinkler is a single skid mounted sprinkler or a travelling irrigator, the spray jet must be flexible enough to pass solids larger than the nozzle diameter.

Injection of dairy effluent into centre pivots and permanent sprinkler systems requires that the sprinklers be set up to handle the type of effluent injected. Effluent, which is free of solids either by settling or filtration, can be spread through all types of conventional sprinklers. Effluent, which contains solids, will need to be spread through sprinklers that have been set up to handle solids.

What changes will I have to make to my irrigator so that I can irrigate with dairy effluent?

Conventional sprinklers will need to be fitted with flow control nozzles to allow for solids, which can block regulators and nozzles.

Impact sprinklers are able to handle solids that are smaller than the smallest nozzle diameter. These will generally have lower efficiency and uniformity than conventional sprinklers.



Centre Pivot Irrigator

Big gun sprinklers are capable of handling larger solids but require higher operating pressures to operate. Both the efficiency and uniformity of irrigation are low. Big gun supply lines can be underslung from conventional centre pivot systems which will allow two separate methods of irrigation – fresh and effluent.

Travelling irrigators will require flexible jets that can pass solids and prevent blockages. Milking liners can be fitted as a “nut and tail” assembly in place of rubber nozzles. The throw from the travelling irrigator will be dependent upon the liner bore size and the pressure at the nozzle, which will be determined by the delivery rate of the pump and the delivery line friction head.



Travelling Manure Irrigator



Milk Liner Nozzle

Move all sprinkler systems regularly to avoid effluent ponding on a small area. The length of time stationary sprinklers should remain in position before being moved and the speed of movement of travelling irrigators or centre pivot systems can be calculated using the “Nutrient Budget Calculator” spreadsheet¹.

Plan an easy way of moving skid mounted sprinklers.

An effective cut-off mechanism is essential on travelling irrigators.

Spray pot sprinklers can also be effective but they tend to have a small wetted diameter and poor distribution pattern.

Slurry tankers

Slurry or vacuum tankers are useful for moving semi-liquid effluent and they can cope with most of the material which ends up in storage ponds. They provide more flexibility than other spreading systems as they can access more of the farm. Slurry tankers are unlikely to be suitable for large herds due to the time required by the dairyfarmer, or the cost of contractors to spread large amounts of effluent.

As with collection sump systems, wet weather storage will be required for the period of the year when rainfall exceeds evaporation and effluent cannot be spread on paddocks safely with slurry tankers.

Tankers are generally expensive but there is scope for either using a contracting service or for neighbours to share one. Make sure that the tanker is well cleaned before it comes onto your farm.

¹ The Nutrient Budget calculator is available through the Dairy Effluent Technical Officer for the project (phone 08 8842 6222), your dairy company field officer, or the EPA.

An example of a slurry tanker fitted with a dribble bar effluent spreading system



Spreading effluent using a slurry tanker fitted with a splash plate spreading system

Irrigation Management Plans

Guideline No 12



If you intend to irrigate dairy effluent during the time of the year when average rainfall exceeds average evaporation, it is advisable that you develop an Irrigation Management Plan.

An Irrigation Management Plan aims to utilise the water and nutrients applied and prevent nutrients from leaching past the root zone of crops and pastures.

You may also wish to consider monitoring effluent impacts on groundwater, surface water and soil so as to determine the sustainability of your irrigation effluent practice.

An Irrigation Management Plan (IMP) does not need to be developed if you will be storing your effluent during that part of the year when average effective rainfall exceeds average evaporation.

If, however, you intend to spread effluent during that period you should check the feasibility by developing an Irrigation Management Plan. The IMP should describe how the effluent will be spread and demonstrate that the nutrients applied in the effluent will be taken up by pastures or crops.

The objective of the Irrigation Management Plan is to utilise the water and nutrients applied and prevent nutrients from leaching past the root zone of crops and pastures.

The Irrigation Management Plan should be developed by a person skilled in irrigation and plant nutrition and provide sufficient details to enable other persons to verify the sustainable operation of the irrigation system. See Guideline 23 for possible contacts to develop an IMP.

What information should be included in an Irrigation Management Plan?

The dairy effluent Irrigation Management Plan should include sufficient information to demonstrate that the pasture or crop is capable of assimilating the nutrients applied.

The minimum level of information to include in a dairy effluent Irrigation Management Plan is:-

- Volume and nutrient composition of the dairy shed effluent
- Depth and quality of groundwater beneath the irrigation area
- How the effluent will be applied
- The water balance for the irrigation area
- The hydraulic loading rate of the irrigation system
- The amount of nutrients which will be applied at each irrigation
- Approximate frequency of irrigations

- Evapotranspiration rates of the crop or pasture
- Average daily growth rates for the crops or pastures for each month of the year
- Types of crop or pasture and their ultimate use
- The nutrient balance for the irrigation area
- A sampling and monitoring program of soils, vegetation and groundwater to monitor the fate of the nutrients applied during irrigation.

Minimum Monitoring Requirements

Sampling and monitoring will be important considerations in verifying the sustainability of the irrigation system.

Groundwater

A typical groundwater monitoring program could include:

- recording groundwater levels and collecting samples from monitoring bores installed at suitable depths and locations to provide representative water level and water quality data for all aquifers likely to be affected
- take samples at least twice yearly and have them analysed at least for nitrate and salinity. See Guideline 23 for laboratories which can analyse groundwater samples.

Surface water

Take representative samples of runoff from the irrigation area when runoff may impact on surface waters of high environmental value or those used for potable water. Typically these samples would be taken during the winter period. Take samples upstream and downstream of the affected area to monitor the impact of the irrigation. Frequency of sampling should be at least twice during the period when average rainfall exceeds evaporation.

Analyse surface water for oxidised nitrogen and total Kjeldahl nitrogen to give an indication of the runoff of effluent.

Soil

The maintenance of soil quality is essential for long-term sustainability of irrigation schemes. The IMP should provide for soil sampling and analysis on a regular basis to ensure that no harm is being done to the soil structure and chemistry. Recommended parameters, at a minimum frequency of every three years, for soil sampling are:

- Conductivity (salinity)
- pH
- Phosphorous
- Nitrogen (total)

Management of Intensive Use Areas

Guideline No 13



Management of dairy effluent is not only an issue at the dairy but also in areas such as laneways, feed sheds or feed pads, night paddocks and roadways where stock are concentrated for any length of time.

It is important to actively manage the effluent from these areas so as to minimise the pollution risk it may have on water supplies and groundwater systems.

This guideline aims to provide some useful suggestions in management of effluent in areas of intensive use.

General principles

Intensive use areas are where stock concentrate for any length of time - laneways, feed sheds, feed paddocks, sacrifice paddocks and night paddocks. On many farms, stock spend more time in these areas and deposit more effluent than they do at the dairy. Without proper management, this effluent can cause just as many problems, as that dropped at the dairy and it can be more difficult to manage.

Aim to manage the cows so that their effluent is naturally distributed over as much of the grazing area as possible. A system of laneways that promotes free cow flow to and from the dairy and a paddock layout that allows, as far as possible, all paddocks to be grazed in rotation will help.

The more effectively effluent is distributed around the farm, the less the risk of groundwater pollution.

Intensive use areas are generally close to the dairy and it is important that effluent from these areas does not find its way into farm water supplies. Nutrient and bacterial contamination of farm and dairy water supplies can lead to health problems for the family and quality problems in milk.

Laneways

Laneways can generate large quantities of effluent because they are heavily used by stock and they are generally designed to shed water quickly.

Water draining from laneways should be directed onto pasture paddocks at frequent intervals along the laneway to prevent the build-up of large volumes of water at one point and the associated load of sediment and nutrients. Drainage water from laneways should not be directed into watercourses or swamps.

Runoff from laneways must not be allowed to enter calf paddocks due to the risk of Johnes Disease

Try to reduce the amount of manure deposited by reducing the time that cows spend in the laneways. Some ways may include:-

- Allowing the cows to move freely at their own pace along laneways. Trying to hurry cows will upset them and cause increased deposition of manure and urine.
- Encouraging the cows to move away from the dairy after milking by providing a fresh good quality pasture or supplementary feed on a feed pad. Cows will move away readily depositing less manure at the dairy and in the laneways.
- For small herds, hold the cows on concrete at the dairy until milking is finished then move them back to the paddock in a group. This concrete area should drain into the dairy shed effluent system.
- Providing water and shade in the paddocks rather than in laneways.
- Avoiding right angle bends in laneways. Cows tend to bunch up at right angle bends, slowing down movement and increasing the amount of effluent dropped. Good cow flow from the paddock, through the dairy and back to the paddock maximises the time cows spend in the paddock and minimises the amount of effluent dropped in laneways.

Runoff from the intensively used laneways around the dairy and associated structures should be directed to the effluent management system.

Consider stabilising or otherwise treating these laneways so that the solids can be scraped off. It may also be possible to design drains in this area so that solids that collect in them can be removed, rather than being flushed away.

Feed Sheds or Feed Pads

Many farms have invested in sheds or feed pads where cows are fed supplementary feed as well as having access to pasture. Stock in these areas are usually standing on concrete or a hard surface so it is relatively easy to collect and handle effluent. If the feeding facilities are close to the dairy the drainage should be directed into the storage ponds, which need to be large enough to hold the effluent produced from all sources – shed, yards, laneways and feeding areas.

Solids can be scraped to a holding area and stockpiled for later spreading on the farm or sale off the farm. Drainage from the manure holding area should be directed to the storage pond.

Intensive feeding areas that are distant from the milking shed effluent system or where the effluent cannot be managed in the milking shed effluent system due to pond size constraints need to have their own effluent collection and management system. Intensive feeding systems have the potential to cause environmental harm and should be planned and constructed to minimise environmental impacts.

Guidelines for planning feed pads and feedlots are outside the scope of these dairy shed effluent guidelines. Contact Rural Solutions SA on 08 8842 6222 or your farm consultant for more information on planning feed pads and feedlots.

Night paddocks

Night paddocks are paddocks close to the dairy that are used to regularly paddock the herd overnight. The continuous grazing which night paddocks receive is not conducive to high pasture production, even though these paddocks are usually the most fertile on the farm. In many cases there is a continual build-up of nutrients in the area, as more nutrients are deposited than are removed.

Soil testing will usually show that these paddocks do not need added fertiliser. The convenience of night paddocks is outweighed by reduced pasture production from continuous grazing and by having too many nutrients concentrated in a small area where they cannot be used effectively.

Night paddocks should be used in rotation or use an alternative area and sow a crop that is capable of using some of the high nutrient levels. Some crops that may be suitable include maize for silage, sorghum or millet.

Try to limit the use of night paddocks by providing good fresh pasture for the milkers.

Silage pits and stacks

Effluent draining from silage stacks smells unpleasant and means the loss of valuable nutrients such as minerals, sugars and nitrogen compounds. It is a very strong pollutant and must never be allowed to enter water resources.

Silage pits should be constructed and located to prevent discharge to waterways and drains. Keep silage pits well away from watercourses, and do not dig silage pits in areas with high water tables. If the silage bunker is constructed with concrete slabs the joints should be sealed with a flexible compound.

The volume of silage effluent can be minimised by wilting the crop before carting it to the storage area. The minimum dry matter should be at least 25% in the material being ensiled.

Effluent draining from silage stacks or bunkers should be either contained within the vicinity of the bunker with earthen bunding, or drained into an effluent treatment system which has been designed to manage and treat organic wastes by anaerobic treatment.

Wrapped or sealed silage bales should be sited away from waterways, bores, springs and drains. When unwrapping and feeding out the bales, do it some distance from waterways.

Road Crossings

As well as being a road safety issue, road crossings contribute to dairy cow wastes leaving the property.

Special consideration should be given to road crossings. The South Australian Dairyfarmers' Association (SADA) and Transport SA are examining the issue of road crossings and should be contacted if road crossings are necessary.

Creek Crossings

If cows need to cross creeks to access grazing or the dairy, properly designed creek crossings should be constructed.

In-stream crossings

The crossing should be constructed by bed hardening and should not significantly change the profile of the channel.

On soft bed material, the channel should be dug out and rock laid to below bed level to provide resistance to flow passing beneath the crossing and causing destabilisation.

Alternatively, filter cloth can be laid between the rock and the bed material to stabilise the bed. The upstream edge should be buried about 1 metre into the bed and banks and overlaid with rock.

The rock banks should extend to the full height of the embankment (above high water level) to prevent scouring of the banks and to stabilise the access points to the crossing. The banks of the crossing should also be graded to a maximum 4:1 slope, with the lowest section of the crossing being in the centre of the channel.

Both sides of the crossing should be fenced across the full width of the waterway, connecting to existing fencing so that livestock cannot have access along the channel to the riverbanks.

Bridge Crossings

Bridges or culverts are the best way to get cows across a permanent stream.

Nib walls or raised edges on the bridge will prevent manure being washed into the stream.

Runoff from the bridge should be directed into permanently grassed areas for settling and filtering.

Calf Rearing Pens

Effluent from paddocks or areas to which adult cattle have access should be totally excluded from calf rearing areas.

Calf areas should be well away from cow areas.

In calf rearing sheds and pens where sawdust or similar material is used as bedding, sufficient depth of material should be used to ensure that all effluent is contained within the bedding so that there is no runoff from the calf rearing sheds or pens.

Spent bedding should be stored in areas from which there is no possibility of leachate entering surface water.

Management of the Effluent Spreading Area

Guideline No 14



It is important to effectively manage the effluent spreading area so as to minimise the risk of pollution in water sources, and excessive build-up of nutrients in soils. The effluent spreading area may need to be managed differently to the rest of the farm.

To maximise the potential benefits of spreading dairy effluent, you will need to consider the following issues:-

- *Maximising Nutrient Removal*
- *Preventing Loss of Nutrients Below the Root Zone*
- *Minimise Disease Risks*

The effluent spreading area is the area on which the effluent collected at the dairy shed is spread. The area used may vary each time effluent is spread, for example when a waste tanker is used. It could also be a permanent area, where an irrigation sprinkler system is used for spreading the effluent.

The effluent spreading area, particularly where the same area is used for a prolonged period, must be managed to avoid soil and water degradation that will occur if the area is not managed carefully. The effluent spreading area will usually need to be managed differently from the rest of the farm.

The management of the effluent spreading area should aim to:-

- Maximise the removal of nutrients harvested in agricultural produce.
- Prevent runoff of nutrients.
- Prevent loss of nutrients below the root zone of the crop or pasture.
- Minimise disease risks to humans and livestock.

Maximising Nutrient Removal

The nutrients removed from the effluent spreading area can be maximised by growing crops or pastures that can utilise high nutrient levels and produce high dry matter yields. The growth must then be harvested in order to remove the nutrients from the effluent spreading area.

Harvesting of crops or pasture grown can be done by:

- Grazing livestock to remove nutrients in live weight gain or other produce such as milk or wool. An intensive grazing rotation on the effluent spreading area with a withholding period of at least 14 days can be employed. The withholding period allows for some of the pathogens in the effluent to be killed by the environment and allows the pasture to become more attractive to the stock after spreading the effluent.
- Harvesting the crop for green chop, hay or silage. In most cases this will remove more nutrients in harvested product than the grazing of livestock would achieve.
- Grazing livestock in rotation and closing the rotation to allow some or all of the effluent spreading area to be cut for hay or silage. As the growth of the crop or pasture speeds up in spring some of the effluent spreading area may be able to be closed to grazing and be cut for hay or silage. In most cases this will remove more nutrients in harvested product than the grazing of livestock alone would achieve.

Balancing Nutrients – the Nutrient Budget

The nutrient budget is covered in more detail in the **Guideline No.16 – Nutrient Budget**. The nutrient budget for the effluent spreading area can be calculated using the “Nutrient Budget Calculator” spreadsheet. To run the Nutrient Budget Calculator for you dairy contact the Dairy Effluent Technical Officer for the project on 08 8842 6222, your dairy company field officer, or the EPA.

This spreadsheet model is written in Excel and requires Microsoft® Windows 2000 or later running Microsoft® Excel 2000 or later.

Preventing Loss of Nutrients Below the Root Zone

To ensure that crops and pastures are able to utilise the nutrients applied in effluent, the management of effluent spreading is critical.

The key point which must be observed in the timing of any spreading of effluent:

PLANTS MUST BE ABLE TO UTILISE THE NUTRIENTS SPREAD IN EFFLUENT.

If plants are unable to use the nutrients readily, then spreading should be delayed until plant growth conditions are favourable and the nutrients in the effluent can be readily used by the plants.

The most common conditions when effluent spreading should be avoided are:

1. Effluent must **NOT** be spread on land, which is waterlogged or flooded. Plants are unable to utilise the nutrients in effluent while they are flooded or water logged and the likelihood of nutrients running off into other areas is greatly increased.
2. Effluent must **NOT** be spread on land when low soil and air temperatures restrict the growth of crops or pastures. Plants that are not actively growing are unable to utilise the nutrients, which are applied in the effluent. This increases the opportunity for these nutrients to be moved off the area in surface water or pass below the root zone.
Plant growth will be slower in winter due to cold winter temperatures. High rainfall at this time of the year also increases the risk of nutrients being flushed below the root zone before they can be utilised by the plants.

Refer to Guideline No. 7 – Temperature and Pasture Growth.

3. Effluent must **NOT** be irrigated onto crops or pastures at times when sound irrigation practice indicates that the plants will be unable to utilise the water or nutrients applied. This means that for those months of the year when rainfall exceeds evaporation and plants do not require additional irrigation to maintain production, irrigation of effluent should be avoided.

In the Northern area, effective average rainfall exceeds evaporation in only the high rainfall areas for a period of about 60 days. During this period the irrigation of effluent should be avoided, which means that the effluent produced at the dairy during this period should be stored in a pond system and spread in October and/or April. Winter storage ponds should be empty by the end of April each year.

Most areas in the Northern and Yorke region will not require winter storage.

Refer to Guideline No. 6 – Rainfall and Evaporation.

Development of an Irrigation Management Plan

Dairies that wish to spread effluent over the winter period when rainfall exceeds evaporation will need to develop an Irrigation Management Plan (IMP) for the effluent irrigation area, which will demonstrate the feasibility of the irrigation practice. The IMP should be prepared to EPA standards as outlined in Guideline No.12, and include the water balance incorporating climate variables, proposed application rates, average evapotranspiration and percolation rates and the nutrient balance. This should be planned on a monthly basis.

Refer to *Guideline No. 12 – Irrigation Management Plans.*

Minimise Disease Risks

Dairy shed effluent contains bacteria, viruses, parasite eggs and cysts. Most of these are harmless but some are potentially dangerous and can survive for lengthy periods in moist and shaded environments.

Most notable among these are *Salmonella* sp, *Yersinia* sp, worm eggs, coccidia and *Cryptosporidium* spores, as well as the organism *Mycobacterium paratuberculosis* which causes Johne's disease.

Adult cattle generally have a high resistance and may develop some immunity to infection from dung borne organisms. If effluent is spread on the farm of origin it is likely that adult cattle will have already been exposed to the organisms it contains. Young cattle and calves are more at risk because they have not had time to develop their immune systems. It is for this reason that young cattle should be kept separate from adults and not allowed access to areas where effluent has been spread within the past 12 months.

Under the national Dairy BJD Assurance Score system and Dairy ManaJD dairy herds will need to rear their calves under a nationally agreed plan which includes the requirements:

- Management of the calf rearing area should ensure that no effluent from animals of susceptible species comes into contact with the calf, and
- Calves up to 12 months old should not be reared on pastures that have had adult stock, or stock known to have carried BJD during the last 12 months.

Management practices can help to reduce the animal health risk of spreading effluent. These practices could include the following:

- Graze pastures low before spreading effluent so they will not need to be grazed for several weeks after effluent spreading. This allows time for rain to wash microbes and contaminants off the foliage and ensures that sunlight can penetrate to the soil surface.
- Spread effluent in hot and dry weather so that ultraviolet radiation and drying both help reduce the survival of microbes.
- Storage of effluent will help kill dangerous microbes.
- Dilution of effluent with a large volume of water will reduce the concentration of microbes applied to the pasture.
- Use crops that will be mechanically harvested at maturity such as millet, sorghum or maize.
- Watch for signs of Nitrate poisoning in grazing stock. Effluent, particularly fresh effluent is high in nitrogen and can cause problems in heavily fertilised pastures. Signs include increased respiration and heart rate, trembling and weakness, brown conjunctival and mucous membranes, brown blood, unco-ordination, collapse and sudden death.

Human Health

Workers and operators need to undertake safe work and hygiene practices to protect themselves against any potential animal diseases which are transferable to humans. The greatest risk is associated with spray irrigation where aerosols containing pathogens may be created.

Dairy effluent should not be a threat to human health so long as sensible practices are observed when handling the material. These include

- Not smoking, eating or drinking while working with effluent

- Covering any open wounds to avoid contact with infectious materials
- Washing hands and clothing when the job is complete
- Avoiding aerosols generated by sprinklers during effluent spreading. The risk is from both inhaling droplets and absorbing them through the skin.
- Cleaning equipment before moving to another farm to avoid transfer of microbes.

Management practices to prevent risks to animals or public health can be necessary in some cases.

Veterinary advice should be sought where any doubt occurs about risks of animal disease.

Management of Solids

Guideline No 15.



Removing solids from your dairy effluent increases the flexibility of effluent treatment systems. It also reduces blockages, decreases sludge build-up in ponds and separates slowly degraded material from the more quickly degraded material.

This guideline reviews how separated solids can be handled and utilised as a useful fertiliser by-product.

The solid components of dairy shed effluent include manure, gravel and sand. The gravel and sand can be removed at the dairy yard with a stone and sand trap from where it can be returned to the laneways or paddocks.

The manure solids can remain in the effluent or a proportion can be removed in a solids separation system. Removal of solids increases the flexibility of effluent treatment systems. Separation of the larger manure solids also reduces blockages, decreases sludge build-up in ponds and separates slowly degraded material from more quickly degraded material.

Refer to Guideline No.8 : Solids Separation Systems for more details of the different systems which can be used.

Dairy effluent solids are a valuable source of nitrogen, phosphorus and potassium. A sample of stockpiled solids from the Riverton Dairy Effluent Trial had 1.9% nitrogen, 0.27% phosphorus and 0.82% potassium, which is equivalent to a fertiliser value of more than \$34 per tonne of dry matter.

Slurries

Solids separation tanks or ponds which lead into a secondary storage pond will most likely need to have their solids removed as a slurry. The tank or pond relies on gravity to separate the solids from the liquid effluent. Sludge will build up on the floor and a crust may develop on the surface.

The tank or pond will need to be agitated to re-suspend the solids before they can be removed by vacuum slurry tanker or manure pump. If the surface crust is too thick or stable to break up into a slurry it may need to be removed mechanically before the tank or pond is agitated. The slurry should not contain more than around 8% total solids. Slurries over this level may be difficult to remove by tanker due to their thickness or viscosity. Fresh water may need to be added to a thick slurry to enable it to be handled.

Separated Solids

Solids separated using a solids separation system can contain a considerable amount of water (e.g. from a trafficable solids trap) or be relatively dry (e.g. from a screw press separator). Both can be land spread in their current state but it is often

better to allow the wet solids from the trafficable solids trap to drain so that they can be handled with conventional manure spreaders.

Pond Sludge

Solids should be placed on a drainage pad (see below) for de-watering

Pond sludge is a stable, high strength fertiliser. It is normally removed from the pond when the sludge reaches half the depth of the pond, which is from 5–7 years for primary ponds receiving untreated effluent or 10-12 years for ponds receiving effluent after solids separation. Secondary ponds rarely need desludging.

Sludge may be applied directly to soils using a sludge tanker or de-watered and spread with a waste spreader.



Sludge Injection Tanker

Sludge may be de-watered by storing it on drainage pads and allowing the liquid to drain back into the pond.

Drainage Pads

Drainage pads are used for de-watering pond sludge or solids removed from a solids trap.

Drainage pads must be constructed of impermeable material to prevent nutrient rich drainage water from soaking into the soil. All drainage must flow back into the pond or the solids separation system. Drainage pads must have external bunding.

Drainage pads are commonly constructed using a concrete base and concrete block walls and bunding.

Storage

Solids may be stored until land spreading is possible. They should be stored with bunding and adequate drainage to prevent leaching of nutrients into the soil. Any drainage should be directed to the effluent system.

Stockpiles can be formed by spreading and compacting layers of moist solids. Compacting is necessary to exclude as much air as possible. This reduces heating and the risk of spontaneous combustion. Several small stockpiles are preferable to one large one. Small, uncompacted stockpiles can be used to allow the moisture content to fall to 25-30% at which point the solids can be incorporated into the larger compacted stockpile.

The most convenient shape for a stockpile is often a windrow, which runs up and down the slope of the storage area to assist drainage.

Composting

Composting involves the aeration of stockpiled solids to cause the organic materials to be converted by microbial action into stable humus. Aeration is usually achieved by mechanical turning of the stockpiled windrows.

Where management of solids involves composting, the compost site should be established on an area from which all runoff can be collected in a pond. Composting has the potential to cause environmental harm if it is not located, designed and operated properly.



Composting Dairy Effluent Solids

Depending on the annual amount of material composted the activity may require development approval from the local council and licensing by the Environment Protection Authority (EPA). A Guide for Applicants, Composting, organic fertiliser and soil conditioner works is available from Planning SA or the web site www.planning.sa.gov.au/guide_apps/index.html

which identifies whether planning approval and licensing will be necessary and what information should be provided with a development application for a composting facility.

Details of the composting process are beyond the scope of these guidelines.

For more information contact your farm adviser or an environmental consultant.

Spreading

Spreading solids on land can enhance crop and pasture growth. Once spread there can be rapid losses of nitrogen to the atmosphere unless it can be ploughed in. Spreading solids on an area every few years is more compatible with pasture renovation and cropping than annual spreading. Inorganic nitrogen fertilisers can be used to supplement the nitrogen from the solids for the years between spreading of solids.

Spreading when the soil is dry minimises soil compaction problems.

Spreader Distribution

Evenness of spreading is important where low application rates are required to match plant nutrient requirements. Poor spreading efficiency at low rates can cause very uneven growth and different crop maturity times.

There are four basic types of solid manure spreaders.

1. **Moving bed trays with horizontal beaters.**
These spreaders can handle a wide range of manures and are best suited to high application rates. Manure is not spread much beyond the width of the beaters, so narrow run widths are necessary to achieve an even distribution.



2. **Side discharge spreaders** produce fine particles and generally give good distribution. Wind may affect the distribution of dry manures.



3. **Moving bed fed horizontal spinners** are suited to most manure types. Limited load capacity is a limitation when spreading higher rates.



4. **Moving bed fed vertical beaters** are suited to most manure types



Nutrient Budgeting for Land Spreading

Guideline No 16.

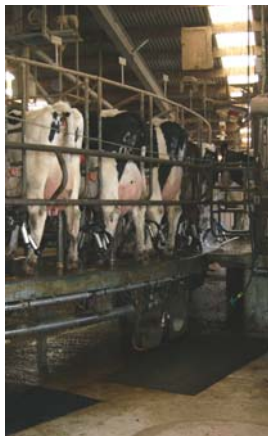

A Nutrient Budget allows you to check the amount of nitrogen, phosphorus or potassium that is applied in dairy effluent with what is being removed through products such as milk, silage, live weight etc.

Allowances must be made for the amount of nitrogen carried over in the soil from previous applications, and the amount of nitrogen that is lost in a gaseous form when it is applied to the land.

This guideline aims to assist in understanding the elements that make up the Nutrient Budget, using the Excel computer program that has been developed as part of these Dairy Effluent Guidelines.

Recycling your Dairy Waste

Manure nutrients and decaying organic matter are natural components of the environment that ultimately contribute to the production of more plant and animal tissue. Although dairy shed effluent is often called a waste, it is in fact a resource when recycled through new plant growth.

Applying manure to supply fertiliser nutrients to plants is the oldest and most used method of recycling. However, if the nutrients are applied in excess of pasture requirements they will be wasted and those not used by the plants are at risk of entering water resources or even degrading the soil.

The composition of dairy effluent differs from farm to farm and from season to season. The amount of nutrients which are in the dairy shed effluent will depend on a number of factors, such as:-

- The number of cows milked.
- How long the cows spend in the dairy and yards.
- How much wash water is used to clean the dairy and yards.
- Whether rainwater from the dairy roof and yards is diverted away from the effluent stream.
- Whether solids separation is used and the type of solids separation.
- Whether the effluent is conveyed direct to the pasture or is held in storage or treatment ponds before spreading.
- Whether some yard wash water is recycled from the second pond.

Manage your Nutrient Levels in your Dairy Effluent

The best way to know what is in your dairy effluent is to have it tested. Effluent should be tested for nutrient content at several times throughout the year. Any laboratory, which carries out soil, plant and fertility analysis should be able to carry out an effluent nutrient analysis. See Guideline 23 for some suitable laboratories.

There are three major nutrients which should be managed in dairy effluent. These are

- Nitrogen
- Phosphorus
- Potassium

Nitrogen

Nitrogen is an essential plant nutrient which is incorporated into plant protein. Nitrogen in effluent is present as ammonium, ammonia, organic nitrogen, nitrate and nitrite. Plants, however, can take up nitrogen in only the ammonium and nitrate forms. The other forms can become available as the organic nitrogen (in the form of proteins) is mineralised into forms available to plants.

To avoid nitrogen in the form of nitrate passing below the root zone and entering the groundwater, or being carried by surface water into streams, it is important that the nitrogen application rate from all sources does not exceed the capacity of the pasture to assimilate it. Once assimilated in the pasture it can be removed by grazing to produce milk or live-weight gain or harvested as green chop, silage or hay.

Reducing the excess nitrogen excreted by the cows can play an important role in managing the nitrogen in dairy shed effluent. Dairy cow rations should be balanced so that the correct amounts of protein and energy are supplied daily. When the protein in a cow's diet exceeds her needs the extra protein is largely excreted as nitrogenous compounds and increases the amount of nitrogen which needs to be managed in the dairy shed effluent.

Phosphorus

Phosphorus, like nitrogen, is an essential plant nutrient. However, in conjunction with high nitrogen levels, high phosphorus concentrations in streams, lakes and dams can cause eutrophication and excessive algal growths. In particular, high phosphorus levels have been linked to the occurrence of potentially toxic cyanobacteria (blue-green algae) blooms throughout Australia over the past decade.

Phosphorus is much less mobile than nitrogen and is therefore less likely to enter water resources. Most soils have the ability to bind or adsorb phosphorus and retain it in the root zone until it can be used by plants. The ability of soils to adsorb phosphorus generally increases with the amount of clay and free lime in the soils. Sandy soils have a low capacity to store phosphorus, and are much more likely to leach phosphorus or allow phosphorus to move.

Most phosphorus is lost from soils by erosion as phosphorus adsorbed on soil particles.

The application of phosphorus in effluent should not exceed the capacity of the pasture or crop to assimilate it, plus a small allowance to increase soil phosphorus fertility levels according to the ability of the soil to store phosphorus. The number of years that the soil fertility build-up can occur will depend on your soil type.

Where phosphorus is the nutrient which seriously limits the rate at which the effluent can be spread, reducing the amount of phosphorus excreted by the cows can play an important role in managing your dairy effluent. Up to 70% of the phosphorus in the cows' ration could be excreted.

The phosphorus to calcium ratio in the ration should be checked to ensure that there is no imbalance. The inclusion of phosphorus supplements which are more available to the cows will reduce the amount of un-utilised phosphorus excreted.

The phosphorus levels in liquid effluent can be influenced by storage. In storage ponds 50–85% of phosphorus in effluent settles to the bottom. It is not available for land application by irrigation unless it is agitated for sludge removal.

Talk with your nutritionist about some means of reducing the amount of phosphorus excreted by your cows.

Potassium

Potassium is excreted mostly in an inorganic form in urine. It is soluble in water and immediately available to plants. In effluent storage ponds most potassium is found in the sludge layer.

Potassium is also an essential nutrient for plant growth and helps plants take up nitrogen. However, high levels of potassium, especially in combination with high nitrogen, can induce magnesium and calcium deficiencies in grass pastures. This can cause hypo-magnesia (grass tetany) in cattle and germination difficulties with crops.

Potassium can be lost by leaching. Excess potassium may also result in luxury uptake by plants. To avoid leaching and luxury uptake, applications of potassium should not exceed the amount which is required for the growth of pastures and crops. Frequent light applications are preferable to a single heavy application.

High levels of free potassium in soils have an effect similar to high salinity. High levels of potassium in soils can also degrade soil structure.

Nutrient Budgeting

A Nutrient Budget can be used to check the amounts of nitrogen, phosphorus and potassium applied to the land in effluent with what is being removed from the soil/plant environment through the removal of products e.g silage, hay, cereal grain, milk, or live weight gain.

So that a complete nitrogen budget is taken in to account, it is also necessary to consider the amount of nitrogen that is already stored in the soil profile and any nitrogen that may be lost in a gaseous form during the effluent application process. Once these amounts are determined, the amount of nitrogen added per hectare per year from all sources including effluent, can be calculated.

The maximum amount of phosphorus which should be applied in effluent should not exceed the amount which can be assimilated by the pasture or crop, with a small addition a amount to increase soil phosphorus levels according to the ability of the soil to store phosphorus.

Applications of potassium should not exceed the amount which is required for the growth of pastures and crops.

The Amount of Nutrients Removed in Products

Table 15.1 below shows the amount of nitrogen, phosphorus and potassium removed per tonne of dry matter for a range of agricultural products.

Table 15.1 Nutrients Removed in Agricultural Products

Product removed	Average DM	Nutrients removed (kg/tonne DM)		
		P	N	K
Cut Forage, Fescue	25%	3.7	24.0	22.0
Cut Forage, Lucerne	25%	2.9	28.8	25.0
Cut Forage, Oats	25%	2.0	27.2	20.0
Cut Forage, Ryegrass	21%	3.0	28.8	20.0
Hay, Barley	87%	2.7	14.4	14.0
Hay, Clover Dominant Pasture	88%	2.2	25.6	12.0
Hay, Grass Dominant Pasture	85%	3.0	22.4	16.0
Hay, Lucerne, early flower	88%	3.0	35.2	22.0
Hay, Lucerne, late flower	85%	2.0	24.0	25.0
Hay, Oaten	86%	3.2	15.2	16.7
Hay, Oats & Vetch	88%	3.0	22.6	16.7
Hay, Peas	90%	2.2	25.6	12.0
Hay, Ryegrass & Clover	83%	3.0	15.2	22.0
Livestock, Cow's Milk (per 1000 litres, at 3% protein)	#	1.1	6	1.9
Livestock, Cattle Liveweight Gain (per tonne)	#	8	60	4
Livestock, Sheep Liveweight Gain (per tonne)	#	5	20	2.5
Livestock, Wool (per tonne)	#	4	200	20
Lupins	92%	3.1	56.0	8.2
Potato tops	30%	0.2	3.0	2.0
Potato, tubers	23%	2.4	15.2	21.7
Silage, Grass Dominant Pasture	40%	3.0	22.4	16.0
Silage, Lucerne	40%	2.2	27.2	25.6
Silage, Maize	30%	3.1	12.8	15.4
Silage, Rye & Clover Pasture	35%	3.0	22.4	16.0

The Amount of Nitrogen Stored in the Soil.

Not all nitrogen is available to plants in the year of application. Some nitrogen is held in undecomposed organic matter which needs to break down before it can be used by plants.

Approximately 60% of the nitrogen in effluent is available to plants in the first year. The remainder is carried over into year 2 (30% is available) and year 3 (the final 10% is available).

The amount of nitrogen carried over from these previous years needs to be accounted for in the nitrogen budget.

The amount of Nitrogen Lost as Gas

During and After Spreading

The amount of nitrogen lost as gas will depend on the method used to spread the effluent and whether it is incorporated into the soil quickly by additional irrigation or rainfall.

Effluent applied through a sprinkler system will lose approximately 25% of its N content by volatilisation. Losses when spreading by manure cart will be around 18% of total N.

About 25% of applied nitrogen can be lost after spreading unless it is immediately incorporated into the soil.

By Grazing Animals

Nitrogen is lost in the form of ammonia by grazing cattle. A dairy cow of 600 kg live-weight will emit around 0.120 kg of ammonia nitrogen per day.

The Amount of Phosphorus Stored in Soil

The ability of soils to store phosphorus is called the “Phosphorus Sorption Capacity” of the soil. The capacity of the soil to adsorb phosphorus depends on the concentration of iron and aluminium oxides. Soils with high clay content or high free-lime content tend to have the highest Sorption Capacities. For most soils, application of phosphorus up to 1/3 of the Sorption Capacity for the soil will result in the soil sorption immobilising the phosphorus and preventing movement of phosphorus through the soil. Applications in excess of 1/3 Sorption Capacity can exceed the capability of the soil to immobilise all the additional phosphorus and result in phosphorus movement in the soil. It is important not to exceed this level.

Table 15.2 shows the Phosphorus Sorption capacity for soil classes in South Australia.

Table 15.2 Phosphorus sorption of soil classes in South Australia

Class	P Sorption Capacity mg/kg soil	Soils
LOW	0–200	Deep sand, some podsols, sandy mallee, solodised solonetz
MODERATE	200–1000	Loamy mallee, sandy red brown earth, clay loams (most cereal-growing soils)
HIGH	1000–2000	Clayey red brown earth, dark brown cracking clay, calcareous loams, lateritic podsollic.
VERY HIGH	2000–4000	Kraznosems, peats, acid swamp soils, highly calcareous soils.

Table 15.2 provides a general guide to the range of Phosphorus Sorption Capacity of South Australian soils. More accurate estimation of the soil’s Phosphorus Sorption Capacity can be made from table 15.3, which shows values for soils at a range of sites within South Australia.

Soil Phosphorus Sorption Capacity will change over time as a result of the use of phosphatic fertilisers or effluent containing phosphorus. Having the soil tested is the only means of determining what Phosphorus Sorption Capacity remains in the soil.

Table 15.3: Phosphorus sorption capacity of some South Australian soils

Soil Type	District	Texture	P Sorption Capacity mg/kg
Deep sand	Tintinara	Sand	5–14
Podsols: Ground-water Yellow Yellow Red Lateritic	Wattle Range Mt Compass Myponga Flaxley Parndana	Sand Drift sand Valley sand	2 11 130–200 750–800 1000–1200
Solodised Solonetz	Cleve Lameroo Kybybolite Mt Compass Mt Compass	Sand Sand Sand Sand Clay Subsoil	22 9 130-370 210-250 2000-4000
Sandy Mallee	Wanbi Napperby	Sand Sand	30 140
Loamy mallee	Kimba Minnipa Roseworthy Caltowie Narridy Maitland	Loamy sand Loamy Sand Sandy Loam Sandy Loam Sandy Loam Loam	270 560 440-550 675 710 900
Grey calcareous mallee	Central Yorke Peninsula	Calcareous Loam	1670
Grey calcareous sand	Lower Yorke Peninsula	Calcareous Sand	3575
Red Brown Earth Sandy Sandy Sandy Loamy Lateritic Clayey	Cleve Ungarra Riverton Booleroo Cockaleecheie Turretfield	Gravelly sand Sandy Loam Sandy Loam Loam Loamy Sand Clay Loam	175 310 445 401 800 1670
Dark Brown Cracking Clay	Manoora Salter Springs	Clay Loam Clay Loam	1000 1120
Ground-water rendzina	Furner Struan	Clay Clay	670 1000
Alluvial Clay	Long Flat	Clay	3330
Volcanic	Mt. Gambier	Silty Loam	1330
Terra Rossa	Coonawarra	Loam	1160
Krasnozem	Glencoe	Clay Loam	4000
Peat	Eight Mile Creek	Peat	2860

(From Primary Industries & Resources SA)

Developing the Nutrient Budget

A nutrient budget spreadsheet model is available from the Technical Service Consultant for the Dairy Effluent Project – contact 08 8842 6222, your milk company field officer, or the Environment Protection Authority. This spreadsheet model is written in Excel and requires Microsoft® Windows 2000, XP or later running Microsoft® Excel 2000 or later.

If you are unable to access or run the model for yourself they will be able to run your data for you.

To run the Nutrient Budget Model

The model will be supplied on CD-ROM. You should create a folder called “Nutrient Budget” on the hard drive of your computer, and copy the model to this folder. There are two ways in which to run the Nitrogen Budget Model on your computer. Choose the method that you are most familiar with.

You can either:-

1. Navigate in Microsoft Explorer to the “Nutrient Budget” folder, and double click the “**Nutrient budget.xls**” file **OR**
2. Select File, then Open, “**Nitrogen budget.xls**” in Excel to open the model.

As the program is opening, the following message will appear.

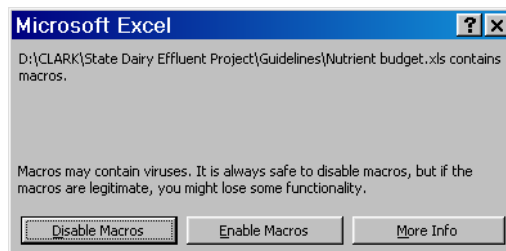

You must click “**Enable Macros**” (or the model will not run). If the model opens without giving you the option to enable macros you probably need to set your macro security level to medium. Close the Nutrient Budget model, and in Excel click on “Tools”, “Macro”, “Security”, and click the bullet button against “Medium”.

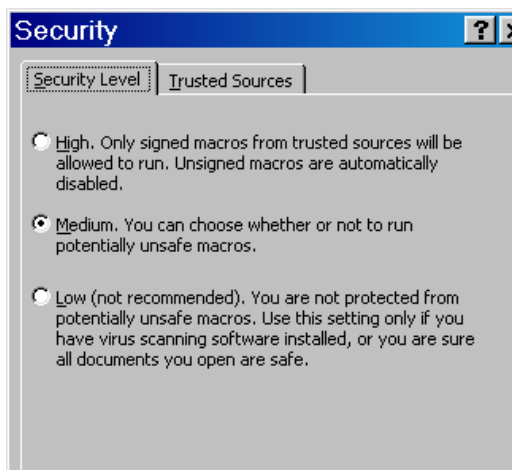

Re-open the Nutrient Budget model.

The model should open at the menu screen.

The menu is used to select the aspects that need to be calculated for your effluent management system.

The options include calculating the amount of:-

- Live weight gain from your effluent utilisation area and milk produced.
- The nutrient budget, including maximum application rates.
- The estimated composition of effluent leaving the dairy shed (This can be used by the model where the actual composition of effluent is not known).
- The value of the nutrients as fertiliser.
- The speed at which a travelling irrigator needs to move to apply the target application.
- How long a stationary sprinkler should stay on one spot to reach the target application.

- How long a run is required by a slurry tanker/waste spreader to apply the target application.
- The speed of rotation of a centre pivot irrigator and the number of rotations, to apply the target application.

The main menu screen layout is shown below. To make a selection, click on the button of choice.

You will be prompted on each screen for the information required to calculate the various aspects of the Nitrogen Budget. For more information on the data required for each input sheet click the "Details" button.

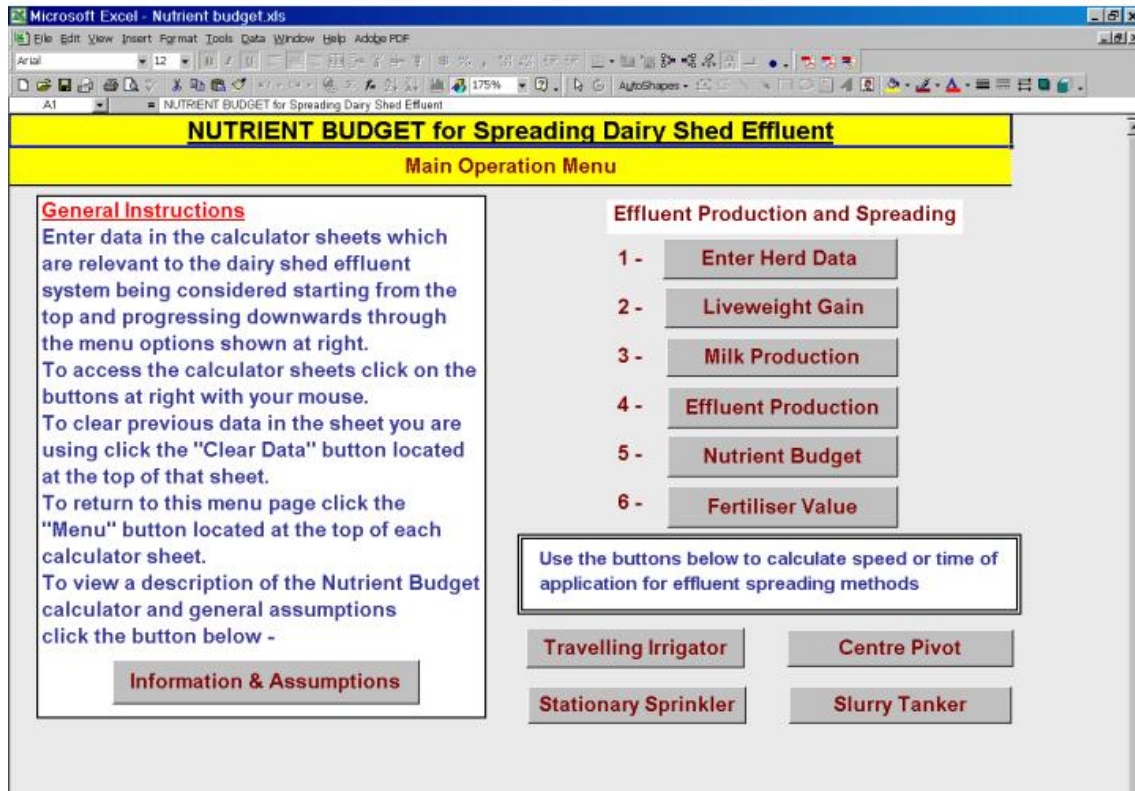

The Main Menu Screen Layout for the Nutrient Budget Model.

Assistance with the calculations

If you are unable to run this spreadsheet model, contact the Technical Service consultant for the Dairy Effluent project 0n 08 8842 6222, your dairy field officer, dairy consultant, or the EPA who may be able to assist with processing your data.

Effluent Management for Large Herds

Guideline No 17.



Effluent systems that are designed for small herds cannot simply be made bigger to cater for larger herds. Issues associated with larger cow numbers, length of time the cows are at the dairy and greater volumes of water required to wash down yards and shed cleaning, all contribute to an overall increase in the amount of effluent that is produced at the dairy.

Management of dairy effluent from large herds can be improved by focusing on :-

- 1. Reducing the amount of effluent by reducing water use*
- 2. Reducing the amount of odour produced through solids management*
- 3. Treatment of the effluent so that it can be irrigated through existing irrigation systems*

Compared to smaller herds, large herds deposit more wastes and nutrients at the dairy, yard and shed cleaning use more water, and create a larger waste volume. Setting up to manage the wastes produced is not simply a matter of making things bigger!

Big ponds are more difficult to clean out. If large storages are required consider more than one pond in series, with each pond of a size which is easier to pump out and de-sludge.

The most confronting issue with effluent management of large herds is managing the huge amount of effluent produced. Dairy shed effluent will produce some odour and the more effluent there is, the more odour that is produced. Odours are generated mainly from decomposing solids in the effluent – the so-called volatile solids.

Managing dairy effluent from large herds can be approached by focusing on two main issues:-

1. Reducing the amount of effluent by reducing water use.

Limiting the water use at the dairy and using recycled effluent for yard wash down will reduce the total amount of effluent which has to be handled and reduce the size of the wet weather storage which will be required over the winter period. This can save many thousands of dollars in pond construction costs and reduce the costs of pumping and annual costs associated with spreading the effluent.

2. Reducing the amount of odour produced by:-

- Separating solids from the effluent early in the waste management system, or
- Treatment of solids in a deep properly designed anaerobic pond, or
- Trapping solids in a “solids pond or trench” which operates as an anaerobic sludge pond with a surface crust.

1. Reducing the Amount of Effluent by Reducing Water Use

The first step in reducing the amount of effluent is to try to limit the amount of fresh water that is used at the dairy. It is also important to limit or eliminate the amount of stormwater that enters the effluent stream.

Limiting the use of fresh water and diverting stormwater are both important in minimising the size of the effluent storage ponds that are required for winter storage when it is too wet to irrigate effluent onto pastures.

Most large herds are milked on rotary platforms, with fresh water being used at the dairy for the following:

- Cup sprays
- Platform sprays
- Plate coolers
- Shed wash-down
- Machine wash-down
- Yard wash-down

Reducing the amount of fresh water used in many of these areas in the dairy will have a large impact on the amount of effluent produced.

Reducing Fresh Water Use – Cup Sprays

Although the flow rates for cup sprays are not usually high they are often running for the whole milking. At a flow rate of 30 litres per minute they will keep the cups clean but use 10,800 litres per day, for six hours of milking.

Reducing the flow rate to 10 – 15 litres per minute using a fine spray will prevent manure sticking to the cups and reduce fresh water use to 3,500 – 5,250 litres.

On the last rotation the flow rate can be turned on full to 70–80 litres per minute, which will wash the cups. This rotation is usually about 10 minutes and uses 700–800 litres of water. The net effect is a reduction from 10,800 litres per day to between 4,200 and 6,050 litres. This strategy will reduce water use over six months by at least 855,000 litres.

Reducing Fresh Water Use – Platform Sprays

Platform sprays keep the rotary platform clean during milking. They are often run for the whole milking using about 60 litres per minute, which amounts to 21,600 litres per day for six hours milking. However, unless there is manure that must be removed, the platform sprays can be left off until the last rotation, when they can be turned on full.

They will use about 80 litres per minute for the 10 minutes of the last rotation, or 1600 litres per day, which is a reduction of 20,000 litres per day.

When this saving is combined with the saving from operation of the cup sprays, the reduction in water use over six months is **4.6 megalitres**, which is equivalent to an effluent pond 50x45x3 metres deep.

Reducing Fresh Water Use – Plate Coolers

Plate coolers operate most efficiently at a water to milk ratio of 2.5–3.0:1. A herd producing 20,000 litres per day will use 50,000 litres of water at a ratio of 2.5:1.

The plate cooler water can be used for a number of things after passing through the plate cooler.

- It can be recycled through a water cooling system for re-use in the plate cooler e.g. a cooling tower system.

- It can be stored for wash-down.
- Water in excess of wash-down requirements can be used for a stock water supply.
- It can run direct to the effluent management system.
- Combinations of all of these suggestions can be used.

Plate cooler water must be good quality fresh water and is often sourced from a bore. It is a good idea to keep the amount going into the effluent stream as low as possible. Recycling of pond effluent to a flood wash tank will dramatically reduce the amount of fresh water used for wash-down at the dairy and allow the plate cooler water to be used in other areas.

Plate cooler water can be eliminated. The plate cooler can be replaced by a refrigerated shell and tube heat exchanger which uses refrigeration technology and glycol to rapidly cool milk to 4°C. This will remove all the plate cooler water from the effluent stream. Contact a refrigeration engineer for details of how this system operates.

Reducing Fresh Water Use – Shed Wash-down

Shed wash down is typically done with hand held hoses with high flow rates – about 300 litres per minute. The volume of water applied tends to move the manure by its depth and momentum.

Restricting the hose outlet using twist type nozzles can increase the velocity of the water, which enhances its ability to transport manure. At the same time, it reduces the water flow rate from the hose by one third to one half.

Flow rates of this nature are unlikely to cause excessive spatter during wash down. Provided that the wash-down of the shed takes no longer, there is a potential saving of 3,000 to 4,500 litres per day for a 30-minute per day wash-down.

Reducing Fresh Water Use – Yard Wash-down

Using twist type nozzles on yard hoses can reduce water use in yard wash-down as described in the section on shed wash-down.

A reduction in the amount of water used in yard wash-down can also be achieved through recycling of effluent from the second pond, of a two-pond effluent storage system.

This will reduce the amount of fresh water used at the dairy by as much as 50%. The continual recycling of effluent for wash-down will result in a more concentrated effluent. As the effluent becomes more concentrated a chemical called Struvite may form in pipes and fittings.

Struvite Control

Struvite is a chemical compound called magnesium ammonium phosphate. When it precipitates in pipes and pumps it can cause problems.

If effluent is continually recycled with little input of fresh water the salts in the effluent accumulate and can precipitate if conditions are right. The main factors which promote precipitation are:-

- pH 7 (normal for effluent). Acid conditions (pH 4) prevent the crystals from precipitating.
- Rough interior pipe surfaces
- Metal components. Plastic components are not immune to build up but are less affected than metals.

- Turbulence. Crystals accumulate where there is turbulence in the water flow so this means around valves, joins, bends and the pump. Turbulence is affected by pump size, pipe size and fittings.

Struvite precipitation can be avoided by:-

- Dilution of the effluent with fresh water. The percentage of fresh water which needs to be added is still uncertain. Problems can still occur with 15 – 20% fresh water inflow into the effluent stream. Check the salinity of the final effluent pond and try to keep it below 3000 ppm.
- Empty the final pond each year so that a long term build-up of salt is avoided
- Match the pump to the pipe size and flow velocity to avoid turbulence. Keep the velocity of flow less than 1.5 m/s and reduce the number of fittings in the effluent line.
- Use PVC or polyethylene piping rather than galvanised steel
- If struvite builds up either recirculate acid to dissolve it, or replace the pipes. Take care with acid. 1 part hydrochloric acid to 9 parts water is effective, but will corrode metal pipes and fittings.

Reducing Water Use And The Effect On Effluent Spreading

Limiting the water use at the dairy and using recycled effluent for yard wash-down will reduce the amount of effluent which has to be handled and also reduce the size of the wet weather storage required over the winter period.

This can save many thousands of dollars in pond construction costs and reduce the annual costs of pumping and spreading the effluent.

The amount of effluent that can be spread per hectare can be checked by running the Nutrient Budget model (**Refer to *Guideline No. 16 – Nutrient Budgeting for Land Spreading***).

Implementing water saving techniques, such as effluent recycling, will result in a reduction in the volume of effluent but will not reduce the area required for effluent spreading. This is due to the effluent becoming more concentrated. If insufficient area is available, removing nutrients from the effluent can reduce the area required for effluent spreading.

How can nutrients be removed from the effluent?

Nutrients can be removed from the effluent by separating solids from the effluent stream, or allowing them to decompose or separate in the storage ponds.

Removal of solids from the effluent can be done by:

- The use of mechanical solids separators, gravity settling systems, and slurry trenches.** The separated solids can be used as fertiliser on other areas of the farm. (**Refer to *Guideline. 8 : Solids Separation Systems***).
- Anaerobic digestion of effluent before passing to an aerobic storage pond.** Anaerobic digestion will reduce the amount of solids, and reduce the amount of nutrients, particularly nitrogen, in the effluent. The sludge and crust will need to be removed from the anaerobic pond after several years, and can be used as fertiliser on other areas of the farm. If necessary it can be moved off-farm.
- Extending storage times to allow breakdown of organic nitrogen and its release as gases.** This process also reduces the number of pathogens in the effluent, but requires a larger storage volume. Extended storage can also decrease the amount of phosphorus and potassium in the liquid effluent as both tend to settle into the sludge layer.

Reduction of nitrogen can also be achieved during spreading by using a spreading system that results in higher volatilisation of nitrogen.

(Refer to section “The Amount of Nitrogen Lost as a Gas” in Guideline No. 16 : Nutrient Budgeting for Land Spreading).

2. Reducing the Amount of Odour Through the Removal Of Solids from Large Herd Effluent

Compared to smaller herds, large herds generally require different management systems to remove solids. Systems that are designed and operate successfully for smaller herds cannot simply be scaled up and used for large herds. This is due to difficulties in handling the increased volumes of effluent and of wet solids. Wet solids in particular are difficult to handle in large quantities – and with large herds large quantities are produced daily.

Removal of solids from large herd effluent can be achieved through mechanical or gravity separation, or both.

a) Mechanical Separation

There are many different types of solids separation machines designed to remove solids from effluent streams (**Refer to Guideline 8 – Solids Separation Systems**). The main types which have been used for dairy shed effluent are the **stationary run-down screen** and the **screw press**.

The **stationary screen** is capable of removing up to 65% of solids but has the drawback of becoming clogged with biological slime, which reduces its effectiveness. It requires regular cleaning to maintain its efficiency. More recently self cleaning screens have been developed (the “Wedge Wire” screen and the “Baleen Filter”) which alleviates blockages.



Run Down “Wedge Wire” Screen

The **screw press** can remove up to 45% of the solids in dairy effluent and requires very little power to operate it.

The disadvantage of the screw press is its relatively slow operating speed. For example, a screw press with a capacity of 115 litres per minute would take about 6 hours to process the daily effluent from an average 600 cow dairy.



Press Screw with Solids Extruding

Throughput of the separator can be adjusted by altering the amount of moisture retained in the separated solids. The dry matter can be adjusted to as high as 80–90% but the throughput will be reduced. Some down time needs to be built into the system to allow for repairs and maintenance.

By contrast, the “Wedge Wire” screen can operate at 1000 – 1300 litres per minute and produces a product at 65 – 70% dry matter. Very little maintenance is required.

Sufficient pre-separator effluent storage is required for at least two days in case of breakdowns. An agitation system is required in the pre- separator storage when the effluent is being pumped to the separator. To avoid “dead” pockets during agitation the pre-separator storage should be circular.

b) Gravity Separation

Gravity sedimentation systems rely on gravity to settle the heavier particles. Gravity settling has the potential to remove more solids than most alternatives but requires more management.

In closed ponds or slurry trenches the surface will crust over and the heavier solids will settle to the bottom. The effluent from beneath the crust is drained into a storage lagoon.

During the cleaning process the crust is removed carefully with an excavator, then the settled solids are vigorously agitated so that they can be handled as slurry and removed with a vacuum tanker or manure pump. Cleaning should be done before the settled solids reach more than 50% of the depth of the trench or a solids content of greater than 8% in the agitated slurry. Slurries with solids content greater than 8% may be difficult to remove with a slurry tanker and vacuum pump. Thick slurries may require the addition of water to dilute them.

To use this system with synthetic liners several slurry take-off points should be installed into the base of the liner at construction with couplings for the effluent tanker located on the bank. This will avoid the tanker having to insert a surface suction pipe into the pond with the risk of puncturing the liner.

Sedimentation systems are usually a basin or terrace system. For basins and terraces settling occurs when the flow of the effluent is slowed as it spreads across the structure and the denser particles settle to the bottom by gravity. Settling basins should be shallow, typically 0.6–1.0 metres deep, long, wide and free draining with the effluent moving on to a storage lagoon. The design flow rate through the basin should be less than 0.3 m/sec with a hydraulic retention time of at least 20–30 minutes.

A front-end loader can be used to remove the solids every 1–2 months. Regular removal is necessary to prevent the development of septic conditions or sludge re-suspension. Two basins or terraces side by side can be used alternately, with one being filled while the other dries out for cleaning.

Anaerobic Digestion

Anaerobic digestion is the breakdown of organic matter by micro-organisms in the absence of oxygen. The end products of anaerobic digestion of effluent include biogas that is comprised of methane, carbon dioxide, some trace gases and stabilized organic matter.

An anaerobic treatment pond is sized to accommodate the volatile solids loading. The pond size depends on herd numbers, cow size and the time cows spend in areas which contribute to the effluent flow into the pond. The design-loading rate is dependent on climate, which affects the biological activity within the pond. This governs the amount of solids that can be loaded into the pond per cubic metre of pond volume.

The engineering details of anaerobic pond design are beyond the scope of these guidelines. For assistance in designing an anaerobic pond you should contact the Dairy Effluent Technical consultant on 08 8842 6222 or a waste management engineer.

When properly designed, managed and not overloaded, the anaerobic pond can function for many years. A low-level musty odour is normal. A foul odour indicates a malfunction.

Handling Solids

Separated solids can be spread on the dairy farm as a soil conditioner and fertiliser or they can be sold off-farm, particularly if they are low enough in moisture content to handle easily with loaders and trucks.

The method of handling the separated solids will depend on the moisture content of the solids. Vacuum tanks are suitable for slurries up to 20% total solids. Vacuum tankers provide flexibility of distribution, which maximises the nutrient utilisation and value of the waste. However, vacuum tankers have a high labour requirement. When the soils are wet, issues such as soil compaction with machinery wheels and traction problems can occur. Vacuum tankers are limited to small waste volumes.

Solid manure spreaders are suitable for materials with solids content greater than 20% total solids. They are the only method of getting an even distribution of solid material. The disadvantages are the high labour requirement, soil compaction caused by the machinery wheels and traction problems are common in wet soils.

For more details on general handling of solids refer to Guideline 15 - Management of Solids.

Spreading the Effluent

Spreading the effluent from large herds will generally require a large irrigation system. This could be a centre pivot into which the effluent is injected, big gun travelling irrigators or a permanent sprinkler system.

Injection of dairy effluent into centre pivots and permanent sprinkler systems requires the sprinklers to be set up to handle the type of effluent injected.

Effluent, which is free of solids, either by settling or filtration, can be spread through all types of conventional sprinklers. Effluent, which contains solids, will need to be spread through sprinklers that have been set up to handle solids

Conventional sprinklers will need to be fitted with flow control nozzles to minimise blockages that will occur when solids are present.

Impact sprinklers are able to handle solids that are smaller than the smallest nozzle diameter. These will generally have lower efficiency and uniformity than conventional sprinklers.



Centre Pivot Irrigator

Big gun sprinklers are capable of handling larger solids but require higher operating pressures to operate. Both the efficiency and uniformity of irrigation are low. Big gun supply lines can be underslung from conventional centre pivot systems which will allow two separate methods of irrigation – fresh and effluent.

An example of a system for large herds

The following is a description of an effluent management system which could be suitable for a large herd.

1. Sand and stone trap. This could be constructed similar to a trafficable solids trap. Effluent enters by natural gravity flow. Heavy particles settle out. Some manure solids would also be captured. Separation of sand and grit is essential because the effluent will need to be pumped at the next stage of processing. Sand and grit, and the accumulated manure solids are removed by loader and stockpiled to drain into the effluent system



2. Effluent flows to an in-ground circular receival sump capable of handling all the wash water for up to two days plus storm capacity if the yard runoff is not diverted. Gravity flow is preferred. The sump is fitted with a mixer to re-suspend any solids which settle out. A by-pass drain to take effluent to the gravity separation system is installed here in the event of long term breakdown of the solids separator, or extreme weather events.



3. Effluent from the sump is pumped to a mechanical solids separation device. The pump and pipe sizes are matched to achieve a velocity in the pipes which prevents settling of solids during transfer. Solids fall to the concrete pad beneath the separator, and runoff from the wet/moist solids is directed either back to the receival tank, or the gravity separation system



4. Liquid from the solids separator gravitates to a gravity separation terrace or pond. A number of designs are possible here, incorporating concrete terraces which control flow rates and settling of solids, or a pond designed to settle out solids over a period of months. Solids will need to be removed from the terraces every couple of weeks, or 6 – 12 monthly from the solids pond.



5. Effluent from the terraces or from beneath the surface of the solids pond is moved by gravity flow to one or more storage ponds depending on area available, and the size and dimensions required for ease of cleaning. The final pond should be relatively shallow to promote aerobic conditions and reduce odours. If odour reduction is important, mechanical aeration may be an

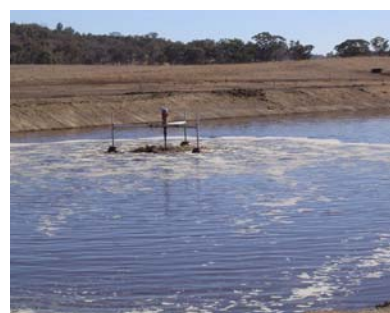

option. Effluent from this pond can be recycled back to yard flood wash systems or in-place yard cleaning systems

6. Effluent from the final pond is suitable for injecting into existing irrigation systems, such as fixed sprinklers and centre pivots. A mixing ratio of between 5 and 8% of effluent in the irrigation mixture is a guide to the proportions required to meet nutrient load parameters and utilise all the effluent in the storage ponds. The actual ratio is

determined by developing an irrigation schedule for the crop or pasture being grown. The effluent pump should be timed to start about 10 minutes after the fresh water pump, and turn off 10 minutes before the end of the irrigation. This allows the fresh water to flush out the pipes of the irrigator and prevent any solids build-up.



Emergency Back-up Planning

Guideline No 18



An emergency back-up plan provides direction when an emergency has occurred, such as a power failure. Putting a plan in place will minimise disruptions to dairy production operations and to the environment.

This guideline provides suggestions for various events that may occur in the dairy operation that will have an impact on the dairy effluent management system.

If you do not currently have an emergency back-up plan, it may be a good idea to review your operation and put one in place.

What is your Back-up Plan?

Operators of dairy farms should have effective procedures and plans in place to respond to emergencies or contingencies, which can impact on the operation of their farm. By having plans in place, the emergency can be managed more effectively with less disruption to production and less impact on the environment.

This guideline lists some of the possible events that should be considered when setting up a management system for dairy shed effluent. The list is not exhaustive as there may be other emergencies that could impact on your operations. It is important that you identify these and put plans in place to deal with them should they arise.

Disruption to Power Supplies

Many effluent systems require electricity to operate pumps for effluent transfer or irrigation. Where the collection point at the dairy is not large enough to hold the effluent from one milking, the effluent must be pumped direct to pasture or storage during yard and plant cleaning. A plan to deal with the loss of power at milking time is needed. An electric generator large enough to manage the milking shed and effluent system is one option.

Installation of a short term holding tank that is large enough to hold the effluent from two days is another option. This tank should be able to be filled by gravity flow (no pumps) and kept empty so that it is always available for an emergency. When the tank is used the contents will need to be agitated to ensure that solids are re-suspended before the effluent is removed.

Round tanks are better than square tanks because square tanks have “dead” corners in which solids can accumulate. Agitation and removal can be done using a slurry tanker.

Disruption to Shed or Effluent Operations by Natural Disasters

What impact could storms, flooding or fire have on the operation of the effluent management system?

Ensuring that the nib wall around the yard is high enough to prevent surface runoff entering the yard can prevent the entry of stormwater from areas above the dairy yard. In hilly high rainfall areas the nib wall may not be adequate and diversion banks or drains may be required upslope from the dairy. Similarly diversion banks can be used around ponds, or ponds can be constructed as a turkey nest to prevent surface stormwater entering the effluent storage system.

Stormwater from the dairy roof should be diverted into a tank for use in the dairy or as stock water. Stormwater could also be diverted into a stormwater drain.

Stormwater falling on the cleaned yards can be diverted away from the pond using a device that sends effluent to the pond during milking and yard cleaning. It can then be switched to divert stormwater from the clean yards away from the pond. This can save 15 to 20% of the pond volume for an average system.

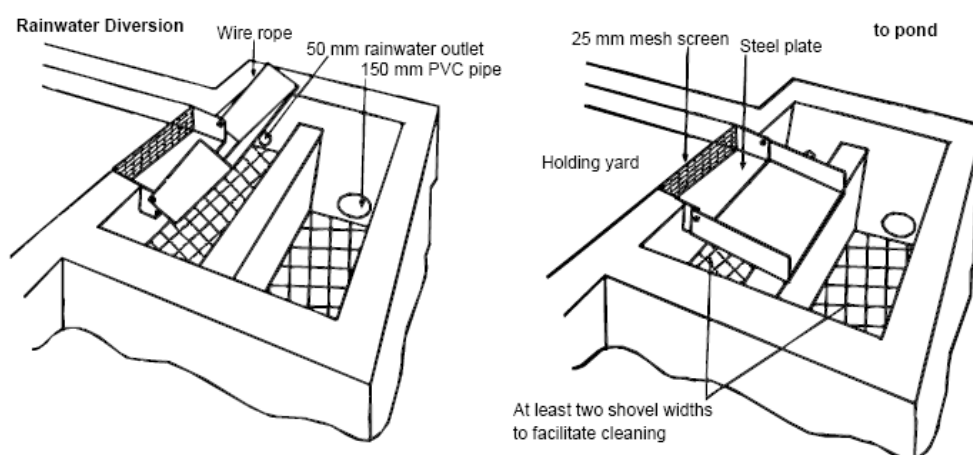

Source Dept of Primary Industries Victoria Agnote AG0433; Dairy Effluent: Minimising dairy shed effluent.

How to Prevent Breakdowns in the Dairy Effluent Management System

Blockages of Drains

- Maintaining free-flowing drains is better than having to deal with an effluent spill brought about by blocked drains.
- Drain blockages can be caused by accumulations of solids, which can result in effluent escaping from the effluent management system. Constructing drains with a slope and profile that can transport solids is the first step in avoiding the problem. Drains with a “V” profile will move solids better than a flat bottom or trapezoid drain profile.
- Avoid sharp changes of direction in drains and allow access for cleaning out any blockages. Prevent vegetation from growing in drains or on the banks.
- Regular inspections may be necessary to keep the drains flowing freely. Whose job will this be and how often?

Blockages of Irrigation Pipes

- Select the correct type and size of pipe for the job it must do.
- Refer to the “Pipes” section **in Guideline No.11 - Equipment**.
- Irrigation pipes and sprinklers can become blocked by solids in the effluent. This affects the evenness of distribution of the effluent or could fracture pipes due to excessive pressure.

- Installing a solids separation system (**Refer to Guideline No. 8 – Solids Separation Systems**) can reduce the amount of solids in the effluent for irrigation and reduce the incidence of blockages. Matching nozzle sizes and types to the solids in the effluent is also important in reducing blockages.
- Avoid right angle bends in irrigation delivery pipes. Right angle bends are notorious for blockages.
- Regular inspections of the irrigation system while it is working are important in reducing the impact of any blockages. Whose job will this be and how often?
- Can you install an automatic pressure cut-out switch which operates when blockages occur?

Pump Failures

- When you mount the pump, put it where you can get good access for maintenance and repairs.
- Pumps can fail for a variety of reasons. If parts and technical support are available locally you could be running again within a day - if they are not, it will take longer.
- Do you have another pump available, which could run the effluent system until the main one is repaired?
- Can you store the effluent in a holding tank with capacity for at least two days? This will give some breathing space to allow repairs on the pump. If repairs take longer than two days, can you contract the use of a slurry tanker to remove the effluent until the pump is repaired?

Slurry Tanker Breakdown

- Breakdown of your slurry tanker probably means you will not be able to empty the collection sump at the dairy until it is repaired.
- What parts of the tanker are most likely to give trouble? Are spare parts available locally? Do you need to have spare parts on hand?
- Can you store the effluent in a holding tank with capacity for at least two days? This will give some breathing space to allow repairs on the tanker. If repairs take longer than two days, can you contract the use of a slurry tanker to remove the effluent until the tanker is repaired?

Overloading of Ponds

- Pond overload can occur because of increased amounts of solids entering the pond (more cows are being milked than the pond was designed to handle), or the ponds were not emptied sufficiently before winter and there is not sufficient available capacity to store the winter effluent. A freeboard of 600 millimetres above top water level must be maintained in all effluent ponds. Allowing the effluent level to encroach into this mandatory freeboard is an offence under the Environment Protection (Water Quality) Policy 2003.
- Overloading of ponds with solids will produce septic conditions in the pond, with the formation of a thick crust and high sludge levels. The biological activity in such ponds is reduced and odours may become a problem. The pond will need to be de-sludged and more frequent de-sludging will probably be necessary in future unless the loading rate of solids can be reduced.
- Can you reduce the solids entering the pond by installing a solids separation system? (**Refer to Guideline No.8 – Solids Separation Systems**).
- Overfilling of ponds can be avoided by ensuring that the ponds are emptied sufficiently to accommodate the effluent that must be stored over the winter period. If storage capacity is still a problem, can you reduce the amount of water used at the dairy? If storage is still a problem can you install an additional storage pond?

How to Minimise Accidents that have an Impact on your Dairy Effluent Management System

Human Error

- Mistakes happen. Pumps may not be turned on – or off, taps may be forgotten, tanks overflow, the irrigator is not moved – many things could happen!
- What are the most likely mistakes that could happen in your effluent management system? Make a list of them and write down what would need to be done to resolve the situation next to each one. Discuss the list with your employees so that they know what is expected.

Hazardous materials entering waste stream

- Spillages of pesticides, disinfectants, veterinary chemicals etc. should be excluded from effluent systems as they may harm beneficial organisms and crops.
- Can any spillages of hazardous materials be contained before they enter the main effluent stream? A short-term holding tank that is large enough to hold the effluent from two days is an option. This tank should be able to be filled by gravity flow (no pumps) and kept empty so that it is always available for such an emergency. Contact a waste removal contractor who is licensed to handle hazardous materials for removal of the hazardous waste.

Loss of Trained Staff

- Trained staff are one of your greatest assets. Their loss will impact on the operation of the whole dairy enterprise. Replacing them can be difficult and employing staff who can manage the effluent system may not be easy – it is not viewed as an “attractive” job.
- Does every staff member know how the effluent system operates? Do you have an operating procedures manual that describes how to operate the system and its components? Are employees inducted and run through the standard operating procedures?
- Can you contract someone to manage the system until a new employee is found and trained?

Milk Cannot Be Collected

- Milk that cannot be collected must be disposed of. Disposing of the milk in the effluent system is NOT the preferred option. Large effluent ponds will accept up to three days milk within a fortnight; more than this is likely to produce odours and a reduction in treatment efficiency. Ponds that have had large amounts of milk added may take many months to recover and severe odour problems could occur for a number of months to follow.
- Milk is about 100 times more potent as a pollutant than dairy shed effluent. As much as possible should be fed to animals. The remainder may be mixed with water at a ratio of one part milk to at least 10 parts water and irrigated onto pasture. Fresh water should follow to wash the milk off the leaves.
- In areas with suitable soils it may be possible to dig a trench capable of holding two days milkings. This method of disposal is not suitable in areas with permeable soils or shallow groundwater.

Leakage From Ponds

- A properly sealed effluent pond is essential. Effluent ponds, if not properly sealed, are a potential source of pollution to groundwater. An effluent pond that never fills is a sure indication that leakage is occurring. All ponds must be sealed with clay or some other impermeable lining material.
- The lining of the effluent ponds will deteriorate over time. HDPE liners are chemically inert but will degrade over time due to the effects of sunlight. Indicative lifespans for sections of liner exposed to sunlight are about 25 years for 1.5 millimetre HDPE liner, and up to 35

years for 2.0 millimetre liner. Clay liners should have a lifespan of more than 30 years but this will depend on the thickness of the clay blanket, which has been installed.

- If an effluent pond is leaking the leak must be fixed. This will entail emptying some or all of the effluent from the pond and spreading onto land at rates which the nutrients can be assimilated by the plants growing there.
- The site of the leak must be located and plugged with clay or a synthetic liner installed in the pond. Synthetic liners should be replaced at the end of their lifespan.

Monitoring the Effluent Management System

Guideline No 19



Installing Groundwater Monitoring bores at effluent storage lagoons is a mandatory requirement of the Environment Protection (Water Quality) Policy 2003.

Monitoring of groundwater and other components of the Dairy Effluent Management System is optional, but can provide valuable information about the efficiency of the system and its environmental performance.

This information could also be used to obtain productivity gains from using the nutrients in the effluent for growing crops and pastures.

Effluent Pond Leakage

Installation of monitoring bores to enable the effluent storage lagoons to be checked for leakages is a mandatory requirement of the Environment Protection (Water Quality) Policy 2003 clause 18 (3) (d), which states:-

(3) A person who constructs a wastewater storage lagoon must comply with the following provisions:

(d) A sufficient number of monitoring bores must be installed and properly placed so that the presence of any leakage can be readily ascertained;

Due to environmental variability, it is not possible to provide guidance on the number and location of bores that will be required at each effluent lagoon. Factors such as slope, soil and geology, depth to water and climate conditions will all influence the location and construction requirements of monitoring bores. Because of this, it is necessary to obtain specialist advice from groundwater monitoring experts prior to the construction of monitoring bores.

Sampling of the groundwater in the monitoring bores should be done following bore installation and its development and recovery. These first samples set the base-line record for the groundwater quality at the site. Thereafter sampling is optional. The down gradient bore should be sampled at the same time annually. If the bore shows elevated levels of nutrients, then further assessment would be required.

The sampling procedure used to ensure that results obtained are accurate is beyond the scope of this document, but is detailed in "Murray-Darling Basin Groundwater Sampling Guidelines" (Technical Report #3, Groundwater Working Group).

Again, the use of a suitably qualified person, experienced in the methods for collection of groundwater samples in a valid scientific manner, is recommended.

Samples should be analysed for the chemical substances shown in the table, “**Guide to Sample Analysis**” in this guideline.

The Effluent Management System

Monitoring the remaining components of the effluent management system is not essential but can be useful in assessing the efficiency of the system and its environmental performance. The results of monitoring can be used to improve the efficiency and productivity gains from using the nutrients in the effluent for growing crops and pastures.

This guideline provides general guidance on components that may be useful in a monitoring program. The details of a monitoring program are outside the scope of these guidelines. For more information you should contact your farm adviser or an environmental consultant.

The sampling protocols and analyses required are shown in more detail in “The Manual For Spreading Nutrient Rich Wastes on Agricultural Land” in the chapter “Sampling and Analysis of Effluent, Manure, Soil, Water and Plants”. This manual is on CD-ROM and can be purchased from Rural Solutions SA Roseworthy Information Centre, phone 1800 356 446.

Effluent Quality

Regular analysis of the effluent in the storage ponds should be carried out. This should be done at least annually, at a time when irrigation is about to start. If consistent results are obtained over a number of years, less frequent sampling may be possible.

The analysis of effluent pumped direct to pasture should also be carried out. Small samples of effluent should be taken at intervals during shed and yard cleaning and accumulated in a bucket. A representative sample can then be taken from the bucket for analysis.

The results of effluent analysis can be used to determine the rate at which the effluent can be spread to match the rate of nutrient removals from the spreading area.

Solids and Sludge Quality

Samples of stockpiled or composted solids or sludge should be collected and analysed annually. Again, if consistent results are obtained over several years, less frequent sampling may be possible.

The results of analysis can be used to determine the rate at which the solids can be spread to match the rate of nutrient removals from the spreading area.

Soils in the Effluent Irrigation Area

Sampling at 2 –3 year intervals at a time that fits in with production or cropping requirements should be carried out. Sampling should be done at about the same time of the year. Take topsoil and deep soil cores to one metre or the bottom of the root zone.

The deep soil samples can help monitor the potential for nutrient leaching. The Phosphorus Retention Index (PRI) of the deep soil samples can provide information on the risk of phosphorus leaching below the root zone. You will need to ask for this analysis, as it is not a standard analysis in South Australia.

Crop and Pasture Yield and Nutrient Content

The dry matter yield and nutrient content of crops or pasture harvested from the irrigation area should be measured each year.

The amount of nutrients removed by grazing animals should be estimated. The nutrient budget model supplied with these guidelines is one method of estimating the amount of nitrogen, phosphorus and potassium removed in milk, live weight gain or wool. The amount of nutrients removed per hectare can be used to fine-tune the application rates of effluent and solids.

Spreading Records

Records of the amounts spread on each area should be maintained with sufficient detail to enable the amounts of effluent, water or solids that have been spread to be determined over the lifetime of the area.

Surface Water

Water quality in watercourses or creeks near the effluent irrigation area and the solids spreading area should be monitored on an "event" basis. The most meaningful results will be obtained when the creek is flowing and when runoff is possible from the areas. Samples should be collected both upstream and downstream from where runoff is likely to enter. The results can be used to determine the impact, if any, the effluent irrigation area is having in surface water resources.

Groundwater

Installing special bores or piezometers for monitoring groundwater quality should be done where there is a significant risk of groundwater contamination. These should be installed to allow monitoring of groundwater at-risk sites such as the effluent irrigation area and solids spreading area. Where the risk of contamination is low it may be possible to use existing shallow aquifer bores to monitor groundwater quality.

Analytes (chemical substances)

The table below summarises the analytes required for the different samples.

Guide to Sample Analysis

Analyte	Water	Effluent	Soils	Sludge	Manure
pH	X	X	X	X	X
EC	X	X	X	X	X
N (Kjeldahl N, nitrate-N, and Ammonium-N)	X	X	X	X	X
Magnesium				X	X
P (Total P, Ortho-P)	X	X	X	X	X
Colwell P			X		
Exchangeable sodium percentage (ESP)			X		
Organic carbon			X		
Chloride			X		
K	X	X		X	X
Sodium				X	X
Sodium adsorption ratio (SAR).		X			
Phosphorus Retention Index, PRI			X		

You may find it useful to do some of your own analyses on a more regular basis. pH test kits and salinity meters are relatively inexpensive.

When submitting samples for testing, it is important to contact the analytical laboratory to confirm which tests are to be undertaken and the storage, packaging and transport requirements. Laboratories are often able to provide additional advice on sample collection and may also provide approved, clean sample containers.

Costs

Guideline No 20



This guideline aims to provide an insight to the costs associated with the purchase and installation of various parts of a dairy effluent management system.

This guideline should be used in conjunction with <Region> Effluent Guideline No. 23, which provides further information of the sources used in providing these costs.

*Costs are all estimates as of **March 2005** (Prices exclude GST) and may vary among distributors.*

The referencing numbers in this fact sheet refer to suppliers listed in 'Guideline 23 – Sources of Information.' This enables the reader to identify the source of the cost estimates.

Trafficable solids trap

Referencing No.	Materials Required	Materials Measurements	Unit Cost	Extended Cost
53	Concrete (40 MPa)	11 m ³	\$178/m ³	(Delivered within 25km) \$1958
39	Reinforcing F72	6 sheets	\$75/sheet	\$ 450
	Y12	19 lengths	\$11.00/6m length	\$ 114
55	Formwork			\$ 498
-	Excavation			\$ 200
TOTAL COST				\$3220

Manure pumps

Referencing No.	Materials Required	Cost
32	Yardmaster 10 HP 3-phase	\$ 430
	Reeves 10 HP 3-phase	\$4200
	Upper and lower float switch (for 10 HP motor)	\$ 450
	Yardmaster pond/pit stirrer (10 HP 3-phase, 1500mm shaft)	\$6800

Piping

Referencing No.	Materials Required	Cost
26	50 mm polyethylene	\$1.50/m
	90 mm PVC (stormwater)	\$3.23/m
	100 mm PVC (sewer)	\$6.39/m
	150 mm PVC (sewer)	\$12.85/m

Sprinklers

Referencing No.	Type of Sprinkler	Cost
32	Manurain sprinkler	\$1500
	Effluent traveller	\$4000 - \$5000

Flood wash

Referencing No.	Item	Cost
59	Most popular selling tank; 22,500 Lt (5000 gall)	
	For a yard with a width of 12 – 14m; with 375 mm diameter downpipe and fittings	\$10 000
	For a yard with a width of 25 – 30m; with 450 mm diameter downpipe and fittings	\$10 700

* The three main downpipe sizes sold are as follows. The prices include tank, installation piping, flumes, valves and stand. (Concrete footings and connection to services is an additional expense)

* The system comes with a 10-year warranty. Commercial grade tanks are used. They also offer a do-it-yourself kit, which could save up to \$2000 on the prices quoted above.

Fencing

Referencing No.	Item	Cost
38	Stock lock	\$0.96/m
	Barb	\$0.15/m
	Plain wire	\$0.09/m
	Strainer posts; 7 foot treated pine	each \$38.00
	Steel posts	each \$ 4.60
	Gate; 1 inch tubing, 12 foot	\$89.50
	Gate fittings	\$27.00
	Strainer support; 10 foot treated pine strut	\$15.00
-	Labour	\$30 - \$40/hr

Typical fencing cost

Typical pond: fencing three sides to existing fence line; 140 metres stock lock, 280 metres plain wire, 280 metres barbed wire, three strainer posts, three supports, 10 steel posts, gate. **MATERIALS COST =\$500**

Typical trap: fencing three sides to existing yard fence; 20 metres stock lock, 40 metres plain wire, 40 metres barbed wire, two strainer posts, two supports, gate **MATERIALS COST =\$225**

Mechanical Solids Separator (FAN Press Screw Separator)

Referencing No.	Items Required	Cost
16	Collection pit	\$10,000 – 15,000
	Stirrer	\$ 5,000
	Stirrer installation	\$ 2,000
	Pump	\$ 6,500
	Pump installation (includes access winch)	\$ 2,500
	FAN separator	\$37,000
	Separator housing and platform	\$20,000 – 22,000
	Plumbing	\$ 3,500
	Electrical fittings and installation	\$ 5,000
TOTAL COST		\$91,500

Additional requirements for recycling separated liquid effluent

Item	Cost
Storage tank (60 – 90 kL)	\$15,000
Pump	\$ 5,000
Plumbing	\$ 2,000
Electrical fittings and installation	\$ 2,000
TOTAL COST	\$24,000

Earthworks

Referencing No.	Type of Service	Type of Equipment	Cost
22	Contractor	20 Tonne Excavator	\$90/hr + Float
	Excavation, turkeys nest pond	Bulldozer, scraper, compaction, water	≈ \$5.00/m ³
	General excavation	Bulldozer, scraper	≈ \$2.50/m ³
24	Contractor	20 Tonne Excavator	\$100/hr + Float
		Long Reach Excavator	\$125/hr + Float
		Tip Truck	\$100/hr (neg)

Linings for Effluent Ponds

Referencing No.	Material Required	Cost
50	High Density Polyethylene (HDPE; 1.5mm)	*\$8.50m ²
51	Geosynthetic (Bentofix)	**\$10.00 m ²
22	20 mm crushed rock	\$18.50/tn
	Landfill Grade Clay (locally sourced)	\$5.00/m ³
	Compaction rate for 600 thick layer	\$15.00/m ²

* supplied and laid; excludes trenching around perimeter to secure the liner.

** supplied and laid, plus placement of a protective layer of crushed rock. Does not include the cost of the rock.

Storage Ponds

Winter Storage, Mt. Gambier District

- Based on 500 cows, 150-day storage, 70 litres of effluent produced per cow per day. Fresh water is diverted from the effluent stream (both yard and roof).
- 35,000 litres of effluent produced per day

Single Pond System

Design Storage: 6300 m³ Pond Surface Area: 1781 m²

Referencing No.	Item	Dimensions x Cost	Total Cost
22	Excavation	6307 x \$ 2.50	\$ 15,768
	Filling Sand	267 x \$12.50	\$ 3,338
50	HDPE liner	1781 x \$ 8.50	\$ 15,138
TOTAL COST			\$ 34,244

Two Pond System

Pond 1 Storage: 2100 m³ Pond 1 Surface Area: 600 m²

Referencing No.	Item	Dimensions x Cost	Total Cost
22	Excavation	2100 x \$ 2.50	\$ 5,250
	Filling Sand	95 x \$12.50	\$ 1,125
50	HDPE liner	596 x \$ 8.50	\$ 5,066
TOTAL COST			\$ 11,441

Pond 2 Storage: 8620 m³ Pond 2 Surface Area: 8620 m²

Referencing No.	Item	Dimensions x Cost	Total Cost
22	Excavation	8622 x \$ 2.50	\$ 21,555
	Filling Sand	1293 x \$12.50	\$ 16,163
50	HDPE liner	8622 x \$ 8.50	\$ 73,287
TOTAL COST			\$111,005

Total for the two ponds system is \$122,446

Installation of 50 mm PVC Groundwater Monitoring Wells

Referencing No.	Item	Cost
14	Soil coring	\$72.00/m
	Drilling	\$65.00/m
	Hole set-up (takes approximately an hour)	\$150

Example: For a 20 metre hole the cost of materials would be approximately \$300, which includes Class 9; 50 millimetre pre-slotted PVC, six metre screen intervals, gravel backfill and bentonite cap and cement finish.

Drilling, materials and installation for a 20 metre well:	\$1,750
Additional expenses	
Travelling	\$1,500 – \$1,800
Accommodation (for two people)	\$180/night

Waste Spreading

Liquid Spreaders – Tractor Drawn

Referencing No.	Size Range	Price Range
15	5,000 – 19,500 Lt	\$40,000 – 80,000

Most common system purchased is the 10,500 litre tanker. The price varies according to type of injection/nozzle system fitted.

Suitable applications:-

Tankers are capable of spreading a range of slurries, from liquid wash water to effluent with a viscosity similar to wet concrete.

Referencing No.	Liquid Spreader Specifications	Outputs
15	10,500 Lt tanker	≈ \$43,000
	Filling time	3 – 4 minutes
	Spreading time	3 – 6 minutes
	Average output	42,000 L/hr

Contract rate @ \$100 – 140/hr (depends on method of application).

Liquid Spreaders – Truck Mounted

Truck units are designed to ISO and EPA standards, and are equipped with automated loading arms.

Referencing No.	Item	Cost
17	Truck Hire, 12,500 litre tanker Filling time approx. 4.5 mins Unloading time approx 3 – 5 mins	\$130/hr
	Pond stirrer	\$50/hr
	Excavator (surface cleaning)	\$90/hr (no float fee)
	Travel fee	\$120/hr Local \$100/hr Lucindale

Solid Spreaders

Spreader Specifications	Output
Size range	7 – 20 tonne
Spreading width	20 metres

*Suitable applications: chicken, dairy and piggery manure

Water Sample Collection

Item	Cost
Sampling technician	\$110/hr
Travel costs	\$1.00 km
Sample Freight costs	\$15.00 (TOLL Mt Gambier – Adelaide)

Laboratory Analysis

Referencing Number	Type of Testing	Parameters Tested	Cost Per Sample
44	Water Testing	Salinity, total suspended solids, pH, major metals and salts (Fe, Mg, Na Cl) and nutrients (N and P).	\$33.50
	Soil Testing	pH, extractable P:K:S:Al:B, organic carbon, salinity, free lime, texture, nitrate, chloride, exchangeable cations and EDTA extractable Cu:Zn:Mn:Fe	\$120.00
	Effluent and Wastewater Sludges	BOD, COD, TOC, N, P, K. Total, Dissolved and Suspended solids.	\$150.00

Legal Requirements and Constraints

Guideline No 21.



Dairy farmers have a legal responsibility to manage their dairy effluent so that it does not pollute the soil, groundwater or surface water. Failure to comply with this could lead to prosecution.

This guideline reviews sections of

- *the Environment Protection Act, 1993;*
- *The Environment Protection (Water Quality) Policy 2003*
- *the Dairy Authority Code of Practice for Dairy Food Safety*
- *the Environment Protection and Biodiversity Conservation Act 1999*

In South Australia there are many land uses and management practices which have the potential to cause soil and groundwater pollution. Most of the major effluent producers are licensed under the Environment Protection Act, 1993, which ensures that wastes are managed in order to minimise any pollution problems.

Dairies have previously been exempt from licensing under the Act because of the problems of trying to deal with so many individual operations. There are other powers under the Act to control pollution from dairies, but these will only be used if alternative courses of action have not worked. Through the implementation of these Guidelines and subsequent Codes of Practice, all dairies will have satisfactory effluent disposal systems, which will not pollute soil or water resources.

Dairy farmers have a legal responsibility to manage all dairy shed effluent so that it does not pollute the soil, groundwater or surface water. Anyone failing to comply may face prosecution under the Act.

Environment Protection Act, 1993

The Objects of the Act include (in part):

Part 2 Objects of Act

10. (1) The objects of this Act are:

(a) to promote the following principles ("principles of ecologically sustainable development"):

(i) that the use, development and protection of the environment should be managed in a way and at a rate, that will enable people and communities to provide for their economic, social and physical well-being and for their health and safety while -

(A) sustaining the potential of natural and physical resources to meet the reasonable foreseeable needs of future generations; and

(B) safeguarding the life-supporting capacity of air, water, land and ecosystems; and

(C) avoiding, remedying or mitigating any adverse effects of activities on the environment

- (ii) that proper weight should be given to both long and short-term economic, environmental, social and equity considerations in deciding all matters relating to environmental protection, restoration and enhancement

10.1.b. To ensure that all reasonable and practicable measures are taken to protect, restore and enhance the quality of the environment having regard to the principles of ecologically sustainable development and -

- (i) to prevent, reduce, minimise and, where practicable, eliminate harm to the environment –
 - (B) by regulating, in an integrated, systematic and cost-effective manner -activities, products, substances and services that, through pollution or production of waste, cause environmental harm; and - the generation, storage, transportation, treatment and disposal of waste; and
- (ii) to coordinate activities, policies and programs necessary to prevent, reduce, minimise or eliminate environmental harm and ensure effective environmental protection, restoration and enhancement
- (v) to require persons engaged in polluting activities to progressively make environmental improvements (including reduction of pollution and waste at source) as such improvements become practicable through technological and economic developments
- (vii) to provide for monitoring and reporting on environmental quality on a regular basis to ensure compliance with statutory requirements and the maintenance of a record of trends in environmental quality
- (ix) to promote -
 - (A) industry and community education and involvement in decisions about the protection, restoration and enhancement of the environment.

Part 1, Section 4

Responsibility for pollution

- 4. For the purposes of this Act, the occupier or person in charge of a place or vehicle at or from which a pollutant escapes or is discharged, emitted or deposited will be taken to have polluted the environment with the pollutant (but without affecting the liability of any other person in respect of the escape, discharge, emission or depositing of the pollutant).

General Environmental Duty

- 25.(l) A person must not undertake an activity that pollutes, or might pollute, the environment unless the person takes all reasonable and practicable measures to prevent or minimise any resulting environmental harm.

6.2 Penalties

Penalties under the Environment Protection Act are many and varied, ranging from a warning notice to clean up activities which are causing or have the potential to cause environmental nuisance or harm, to \$120,000 fines and terms of imprisonment.

On-the-spot fines may also apply if you have ignored or failed to act on clean up notices, warnings about improving pollution-causing activities, or environment protection orders.

Environment Protection (Water Quality) Policy 2003

The Environment Protection (Water Quality) Policy 2003 is one of a number of legislative tools provided for by the Environment Protection Act 1993.

The Environment Protection (Water Quality) Policy 2003 (EPA 2003) imposes general obligations for all activities which produce wastes to avoid the discharge of wastes into any

waters, or onto land from which it is reasonably likely to enter any waters. Dairy effluent must be managed in such a way that it remains on the farm and it does not contaminate surface water or groundwater resources.

This means that the effluent must be managed so that its nutrients can be utilised on the farm.

The Environment Protection (Water Quality) Policy 2003 also sets out specific obligations and requirements that must be complied with as mandatory provisions and may be enforced. A wastewater management system is mandatory for all dairies. The system must be operating effectively at all times that the premises is being used as a milking shed.

Restrictions apply to pond location. More details on these restrictions are available in the Environment Protection (Water Quality) Policy 2003 (a copy can be downloaded from the EPA web site at www.epa.sa.gov.au/pdfs/epwg_report.pdf). Those which are relevant to the location of dairy effluent ponds are summarised in **Guideline No. 4 : Choosing An Effluent management System.**

Limitations also apply to spreading dairy effluent and solids. These are also summarised in **Guideline No. 4 : Choosing An Effluent management System.**

Dairy Authority of South Australia

The Dairy Authority of South Australia's Code of Practice for Dairy Food Safety (June 2005) sets out minimum mandatory standards for the production of milk to safeguard public health.

The following sections from the Code are relevant to the disposal of dairy shed effluent.

“3.2.2 Chemical Contaminants

3.2.2.3 Environmental Contaminants

Hazards relating to the location, water source, previous use of and activities of neighbouring properties of a dairy farm must be identified and managed in order to prevent the risk of environmental contamination of the milk.

3.2.3 Microbiological Contaminants

3.2.3.2 Environmental Contaminants

Water and other environmental factors must not be a source or vehicle for transmission, directly or indirectly, of environmental pathogenic microbiological contaminants to the milk.

Hazards relating to the location, water source, previous use of and activities of neighbouring properties of a dairy farm must be identified and managed in order to prevent the risk of environmental contamination of the milk.”

By complying with these Guidelines for the disposal of dairy shed effluent you will fulfil the requirements of the Authority's Code of Practice for Dairy Food Safety.

Local Government

Under Schedule 21 of the Development Regulations, dairies are classed as activities of "Environmental Significance". This classification carries a compulsory referral to the Environment Protection Agency (EPA). If the dairy's effluent management system is in line with the Code of Practice for Milking Shed Effluent 2003, the EPA will approve the plans and return them to the local council. Provided that the plans then meet local council's building requirements, the plans should be approved.

The Code of Practice for Milking Shed Effluent 2003 applies to the management of liquid, semi and solid wastes from the milking of cows, sheep or goats, in new and existing dairies. The principle purpose of the code is to ensure that:

- The operator of a milking shed complies with the mandatory provisions of the Water Quality Policy.

- Milking shed wastewater and associated sludges do not pollute the environment unless all reasonable and practical measures have been taken to prevent or minimise any resulting environmental harm.

Although Local Government does not have requirements for effluent management, it has a duty to inform the EPA of proposed dairying activities. This will apply if you are constructing a new dairy or rebuilding an old dairy.

The Environment Protection and Biodiversity Conservation Act 1999

The Environment Protection and Biodiversity Conservation Act 1999 (EPBC Act) is a Commonwealth act which protects the environment, particularly matters of National Environmental Significance. This act applies to dairy farmers when dairying activities, including waste management and spreading, are likely to have a significant impact on a matter of national environmental significance, or the environment on Commonwealth land. This may include potential impacts on listed species of wildlife or wildlife habitat.

Approval to undertake such activities is required from the Federal Minister for the Environment. It is the responsibility of the dairy farmer to determine whether their activities trigger the provisions of the EPBC Act and to apply for approval.

The EPBC Act can be accessed on the Department for the Environment and Heritage web site at <http://www.deh.gov.au/epbc/index.html>

The web site also has a search facility **"What's protected near you?"** through which you can search your locality for issues of significance by selecting by local government areas, co-ordinates, or a map.

EPBC Act – Considerations for the Fleurieu Peninsula

The swamps of the Fleurieu Peninsula are endemic to the region and listed as nationally critically endangered. They provide habitat for a number of threatened species, including the Mount Lofty Ranges Southern Emu wren. The swamps are wetlands occurring in high rainfall areas in the catchments of the Tookayerta, Hindmarsh, Parawa, Myponga, Yankalilla, Omkapinga, Currency Creek and Finnis. They are densely vegetated and occur adjacent to waterlogged soils around low lying creeks and flats.

If dairying activities could have a significant impact on these swamps, approval for the activities is required from the Federal Minister for the Environment under the EPBC Act 1999.

EPBC Act – Considerations for the Coorong and Lakes areas

The coastal and marine wetlands of the Coorong and Lower lakes (Lake Alexandrina and Lake Albert) are wetlands of international and national importance.

If dairying activities could have a significant impact on these wetlands, approval for the activities is required from the Federal Minister for the Environment under the EPBC Act 1999.

Taxation Benefits

Guideline No 22.



Once a dairy effluent management system has been implemented, taxation benefits may exist, through sections 40-755 to 40-765 of the Income Tax Assessment Act.

For detailed information on your situation you should contact the Australian Taxation Office or your local accountant.

What are the Taxation Benefits?

Farmers are advised to consult their tax consultants in regard to the tax deductibility of expenditure on effluent storage and control. At the time of publication the situation is as follows.

Sections 40-755 to 40-765 of the Income Tax Assessment Act provide an immediate deduction to a taxpayer carrying on an income-producing activity for expenditure for the sole or dominant purpose of:

- Preventing, combating or rectifying pollution by the taxpayer's business on the site of that business; or
- Treating, cleaning up, removing or storing waste produced by the taxpayer's business.

Without these provisions in the Act, no deductions would be allowable.

The deduction does not apply to expenditure on buildings, structures (including earthworks), plant and equipment. However, use of the property for the environmental purposes listed above will be taken to be the use of the property for the purpose of producing assessable income.

This clarifies the eligibility of expenditure for periodic deductions such as depreciation. The original cost of structural improvements, including earthworks, constructed for environmental purposes will be able to be written off in the same way as general structural improvements.

We consider that this would apply to the systems being implemented to reduce and prevent further pollution of groundwater. Thus any non-capital expenses incurred for this purpose could be claimed as a deduction in the year of the expense in the same way as other expenses of carrying on the business of dairy farming can be claimed.

If you have any questions relating to taxation, we recommend that you contact either your accountant or the Australian Taxation Office.

Sources of Information

Guideline No 23.



The following guideline is a list of various services and organisations that can provide information and assistance regarding the implementation of dairy effluent management systems.

All information is current as of January 2005.

These sources of information and services are listed in good faith for information only and no recommendation or suitability is implied.

The numbers listed in the first column of the table are the reference numbers used in the tables of costs in the fact sheet **<Region> Dairy Effluent Guideline No. 20:- Costs.**

Dairy Information Services	
1.	Rural Solutions SA PO Box 822 Clare SA 5453 Ph 08 8842 6226
2.	Rural Solution SA Consultancy Hotline Ph 1300 364 322 Email info@ruralsolutions.sa.gov.au Website www.ruralsolution.sa.gov.au
3.	Primary Industries SA PO Box 2124 Mt Gambier SA 5290 Ph 08 8724 2921
4.	EPA Contacts Mt Gambier: Phil Gorey 08 8735 1108 Mt Gambier: Carl Smith 08 8735 1181 Adelaide: David Duncan 08 8204 2094
5.	Warrnambool Cheese and Butter Field Services PO Box 9246 Mt Gambier West SA 5291 Contact: Noel Stratford Ph 08 8724 7661
6.	Dairy Farmers Farm Services Manager PO Box 121 Edwardstown SA 5039 Contact: Greg Gilbert Ph 08 8292 7777



Government of South Australia
Primary Industries and Resources SA



Australian Government
Department of Agriculture,
Fisheries and Forestry



South East
Catchment Water
Management Board

7.	Wesfarmers – Dairy Rural 333 Commercial St West Mt Gambier SA 5290 Ph 08 8724 7590
8.	Simon Lalich, DE-LAVAL Mobile 0419 518 112
9.	DJ Botting and Associates Farm Management Consultants PO Box 441 Millicent SA 5280 Ph 08 87334455 Fax 08 87334272
10.	Murray Goulburn 140 Dawson St Brunswick VIC 3056 Field Services Ph 03 9389 6421 Fax 03 9389 6529
11.	De Cicco Industries P/L 10 – 16 Allenby St North Coburg VIC 3058 Ph 03 9350 5766 Fax 03 9350 6057
Drilling and Geotechnical Services	
12.	A.S. JAMES – BEAR Pty Ltd Geotechnical Consultants and Laboratory Services (NATA Accredited) 7 Carrington St Kapunda SA 5373 Contact: Doug Bear Ph 08 8566 2399 Fax 08 8566 2344 Email asjbear@capri.net.au
13.	Davison Drilling & Irrigation Pumps 233 Millicent Rd Mt Gambier SA 5290 Contact: Greg Cram Ph 08 8723 0344
14.	Drilling Solutions 14 Bredbo St. Lonsdale, SA 5160 Ph 08 8382 7829
Waste Management and Effluent Spreading Services	
15.	Vacuum tankers and injection equipment PO Box 986 Mt Gambier SA 5290 Contact: Tom Paltridge Ph 08 8738 8045 Mobile 0419 851 543 Website www.muckrunner.com/products.htm

16.	<p>Australian Waste Engineering PO Box 342 Port MacDonnell SA 5291 Contact: Eddie Fensom Ph 08 8738 2021 Fax 08 8738 2475 Mobile 0417 862 197 Bauer and FAN waste handling equipment, Press screw separator</p>
17.	<p>Liquid Waste Wizard PO Box 8165 Mt Gambier East SA 5291 Contact: Warren England Mobile 0418 838 067</p>
18.	<p>World Wide Organics 2 Webster St Mortlake VIC 3272 Contact: Glenn Grey Ph 03 5599 2662 Mobile 0427 992 662</p>
19.	<p>Waste Management Tips Department of Food and Agriculture PO Box 551 Wodonga VIC 3672</p>
20.	<p>Gendore Enterprises Pty Ltd South Gippsland Highway Tooradin VIC 3980</p>
21.	<p>Muckabout Tankers c/o Marshall Overland Spreading P/L PO Box 779 Devonport TAS 7310</p>
Earthmoving	
22.	<p>Gambier Earthmovers Tracks, feedpads, drainage, pipe channels, ponds 29 Avery Rd Mt Gambier SA 5290 Contact: Bob Glede Ph 08 8725 4093 Mobile 0408 849 675</p>
23.	<p>Heenan Earthmoving Nelson Rd Mt Gambier SA 5290 Ph 08 8726 8298</p>
24.	<p>ME & L Henke Yahl Rd, Yahl Mt. Gambier Contact: Malcom Henke Ph 08 8723 2574 Mobile 040 8854 742</p>

25.	<p>Linke Building Contractors Angaston Rd Nuriootpa Ph 08 8562 1841 Mobile 0418 833 748</p>
Effluent Pumping and Sprinkler Systems	
26.	<p>Peter Jennings Pumps Pty Ltd 351 Commercial St Mt Gambier SA 5290 Ph 08 8725 0722</p>
27.	<p>DairyTech SE Westfalia distributors and suppliers of irrigation and effluent pumps PO Box 9488 Mt Gambier West SA 5291 Ph 08 8723 4562 Mobile 0439 871 423 Email dairytechse@bigpond.com</p>
28.	<p>Davey Pumps Pty Ltd 265 Huntingdale Road Huntingdale VIC 3166 Ph 03 9262 3150 Fax 03 9262 3222</p>
29.	<p>Mono Pumps Pty Ltd 1/280 – 288 Grand Junction Rd Athol Park SA 5012 Ph 08 8447 8333</p>
30.	<p>Pacific Pump Co 1 Slough Street Altona VIC 3018 Ph 03 9398 5211</p>
31.	<p>Kelly and Lewis Pumps 26 Faigh Street Mulgrave VIC 3170 Ph 03 9583 9044</p>
32.	<p>Dairy Pumping Systems (DPS) 9/36 Industrial Park Drive Lilydale Industrial Park Lilydale VIC 3140 Contact: Ron Gerdison Ph 03 9739 6521</p>
33.	<p>Manurigator Jones Irrigation & Machinery Supplies Pty Ltd 158 Queen St Warragul VIC 3820</p>
34.	<p>Alfa-Laval Pty Ltd 60 Keon Parade Keon Park VIC 3073 Ph 03 9460 2900 Vacuum pumps</p>

35.	Dumac Distributors Pty Ltd Factory 6, 13 Gatwick Road Bayswater North VIC 3153 Ph 03 9761 5115 Fax 03 9761 5114
36.	Reeve, B.R. Engineering Level 1, 6 Buckhurst Street South Melbourne VIC 3205 Ph 03 9699 7355 Manufacture and supply Reeves pumps
37.	Illawarra Irrigators Tennyson Park Hanging Rock Road Southern Forest NSW 2577
General Farm Supplies and Machinery	
38.	Gambier Farm Supplies Nelson Rd Mt Gambier SA 5290 Ph 08 8725 6533
39.	One Steel Mt Gambier SA 5290 Ph 08 8725 7500
40.	Ford New Holland Berwick/Cranbourne Road Canbourne VIC 3977
41.	Kubota Tractor (Aust) Pty Ltd 347 Settlement Road Thomastown VIC 3074 Ph 03 9465 8899
42.	Zetor (Aust) Pty Ltd 541 Graham Street Port Melbourne VIC 3207
Water and Soil Testing Laboratories	
43.	Analytical Crop Management Laboratory (ACML) South Australian Soil & Plant Analysis Service (SASPAS) Rural Solutions SA Address: PO Box 411, Loxton SA 5333 Contact: Ms Vesna Cook Ph : 08 8595 9125 Fax: 08 8595 9107 Email cook.vesna@saugov.sa.gov.au Web: http://www.pir.sa.gov.au <i>Analyses: Soil testing, Salinity & pH, Nutrients, Plant-tissue analysis, Nutrient analysis, Water, Animal litter and compost, Effluent, Total nutrients</i>

44.	<p>Collex Laboratory 540 Churchill Rd Kilburn, SA 5084 Ph 08 8260 3133 Fax 08 8359 0985 Web www.collex.com.au <i>Analyses: Wastewater, ground and drinking water analysis, Environmental monitoring, Landfill leachate, Contaminated soils, Liquid nutrients, Effluent, Manure.</i> Accreditation: AS/NZS ISO9002:1994 & ISO/IEC Guide 25:1991, QAS, TGA, and proficiency programmes with NATA.</p>
45.	<p>Australian Water Quality Centre Hodgson Road, Bolivar, SA 5110 Ph 08 8259 0211 Fax 08 8259 0228 Web www.awqc.com.au NATA accredited <i>Analyses: Comprehensive service for the analysis of sewage, effluent, commercial and industrial wastewater and sludge. Measurement of BOD, COD, TOC, N, P, K etc, oils etc, anaerobic process, total, volatile, suspended and dissolved solids. An advisory service is also available.</i></p>
46.	<p>Australian Laboratory Services (ALS) Melbourne Unit 6/2 Sarton Rd Clayton VIC Ph 03 9538 4444 NATA Accredited <i>Environmental testing water and soil</i></p>
47.	<p>SWEP Pty Ltd Analytical Laboratories Keysborough VIC 3173 Ph 03 9710 6007 <i>Soil, water & plant analysis, macro and micro minerals, microbiological bacteria & fungi.</i></p>
48.	<p>Soil Food Web Institute Lismore NSW 2480 Contact: Prof. Elaine Ingham Ph 02 6622 5150 <i>Consultant specialist in soil bacteria and fungi analysis</i></p>
49.	<p>CSBP 2 Altona St Birba Lake WA 6163 Ph 08 9434 4600 Email www.csbp.com.au <i>Soil Analysis (Contracted for SASPAS analysis)</i></p>

Pond Lining Systems	
50.	<p>FABTECH (Dam Liners and Other Materials) 33 South Terrace Wingfield SA 5013 Contact: Paul Van Riet Ph 1300 664 776 Fax 08 8347 3111 Website http://www.fabtech.com.au/index.html</p>
51.	<p>Geofabrics Australasia Pty Ltd (Dam Liners and Other Materials) Adelaide Contact: Rod Fyfe Ph 08 8293 3613 Website http://www.geofabrics.com.au/</p>
52.	<p>Darling Downs Tarpaulins Dam Liners and Other Materials 33 Industrial Avenue PO Box 6267, Toowoomba Queensland 4350 Australia Contact: Max Brady Ph: 07 4634 2166 Fax: 07 4634 7725 International: 61 74634 2166 Email ddt@ddt.com.au Website http://www.ddt.com.au</p>
Concrete and Formwork Suppliers	
53.	<p>CSR Lapacede St Mt Gambier SA 5290 Ph 08 8725 0677</p>
54.	<p>Pioneer 10 Atlantic St Mt Gambier SA 5290 Ph 08 8725 6730</p>
55.	<p>RMD Access, formwork and shoring 66 Bennet Ave Melrose Park SA 5039 Ph 08 8179 8240</p>
Pre-treatment Equipment	
56.	<p>Shepparton Fibreglass PO BOX 1962 Shepparton VIC 3630</p>
57.	<p>Stainless Associates Pty Ltd 33 Temple Drive Thomastown VIC 3074 Ph 03 9465 5155</p>

58.	Hunter Screen Products Ltd Macquarie Road Warners Bay NSW 2282
59.	Timboon Plumbing and Pumps Pty Ltd 68 Bailey St Timboon VIC 3268 Ph 03 5599 2662 Mobile 0427 992 662